



Riga Technical University

Institute of Structural Engineering and Reconstruction

Scientific Seminar
Design of Timber Structures by EN 1995-1-1
RTU, November 17, 2016

The research leading to these results has received the funding from Latvia state research programme under grant agreement "Innovative Materials and Smart Technologies for Environmental Safety, **IMATEH**". **Project ID 1854 (task 3)**.

Dr.Sc.Ing. prof. Dmitrijs SERDJUKS

e-mail: Dmitrijs.Serdjuks@rtu.lv

mob. Phone: +371 26 353 082



Scientific Seminar
Design of Timber Structures
By EN 1995-1-1
RTU, November 17, 2016

Content

- 1. Main types of timber structures;**
- 2. Some mechanical properties of timber materials;**
- 3. Limit state method;**
- 4. Design of axially loaded timber elements;**
- 5. Design of timber elements subjected to flexure;**
- 6. Experimental Verification of design procedure for elements from cross-laminated timber.**

Main types of timber structures

Beams

Solid timber beams

Spans:

Single span girders: up to 4.5 m

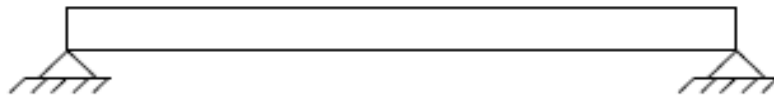

Continuous girders: up to 6.0 m

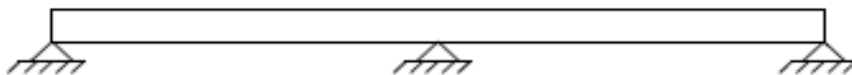

Scientific Seminar
Design of Timber Structures
By EN 1995-1-1
RTU, November 17, 2016

Main types of timber structures

Beams

Glued box, T and I type beams

Spans:

Optimal spans: 3 ... 6.5 m

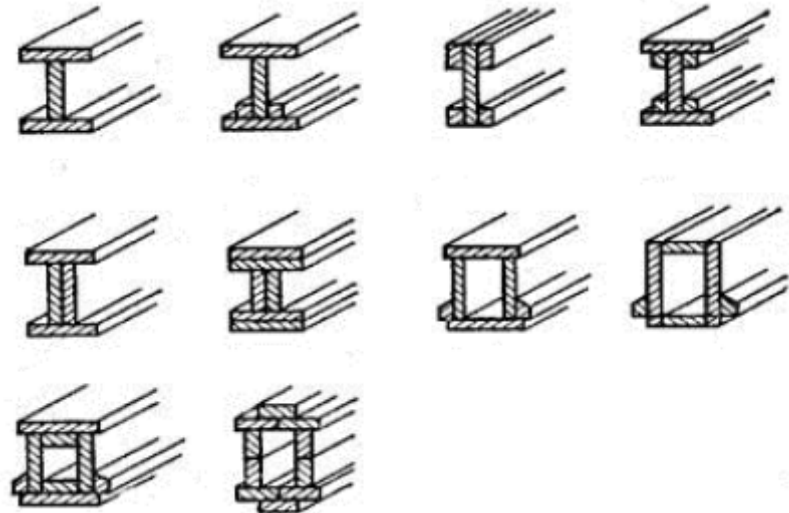

Main types of timber structures Beams

Glued laminated beams:

Optimal spans: 6 – 18 m;
 Possible spans: up to 40 m.
 Beam height: 1/15 ... 1/10 from span.

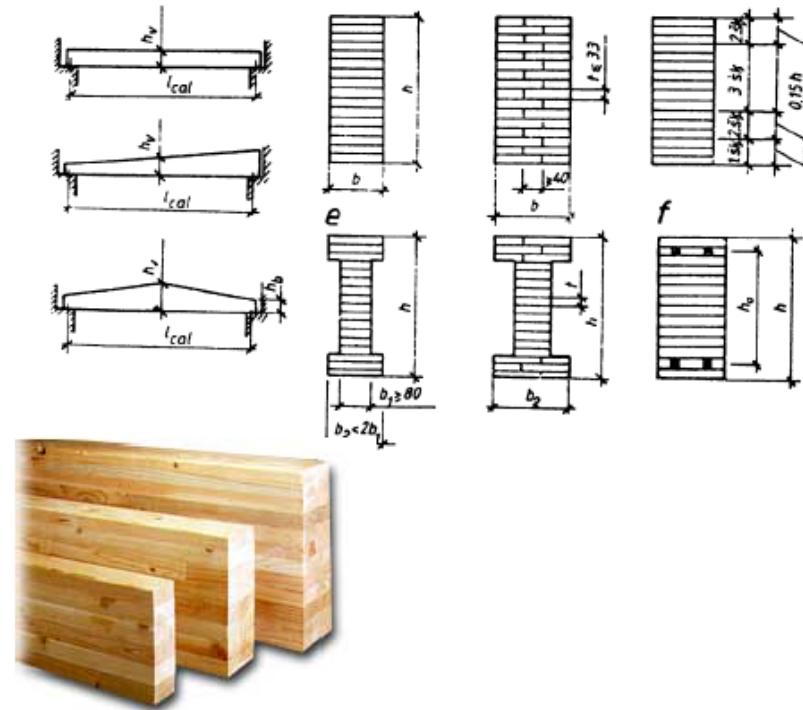

Main types of timber structures

Beams

Timber-Plywood Beams

Optimal spans: up to 15 m;
Possible spans: up to 46 m.
Beam height: $1/8 \dots 1/12$ from span.

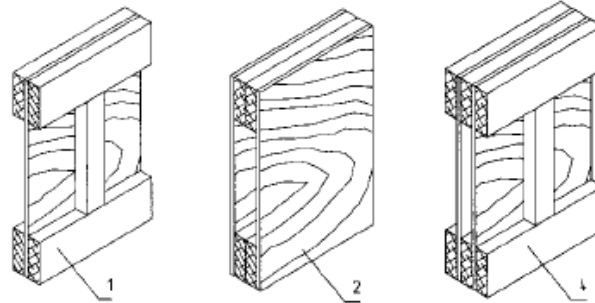
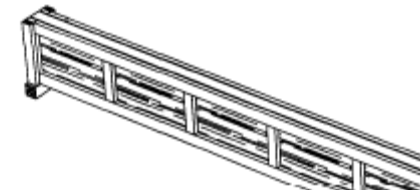

Main types of timber structures

Beams

Composite beams with elastic bonds

Optimal spans: 6 ... 12 m;
Beam height: 1/10 from span.

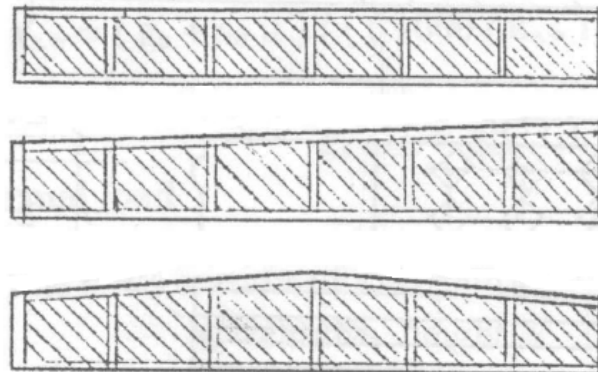

Main types of timber structures

Trusses

Triangular Form Trusses with Glulam Top Chord



Optimal spans: 15 ... 24 m;
Height: $1/5$ from span.

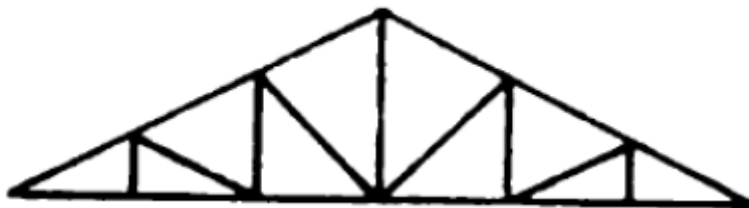

Optimal spans: 9 ... 18 m;
Height: $1/4$... $1/5$ from span.

Main types of timber structures

Trusses

Trapezium Form Trusses with Glulam Top Chord



Optimal spans: 15 ... 24 m;
Height: 1/6 from span.



Optimal spans: 12 ... 18 m;
Height: 1/6 from span.

Main types of timber structures

Trusses

Trussed Beams



Optimal spans: 6 ... 12 m;
Height: $1/4$... $1/8$ from span.

Main types of timber structures

Trusses

Trussed Beams

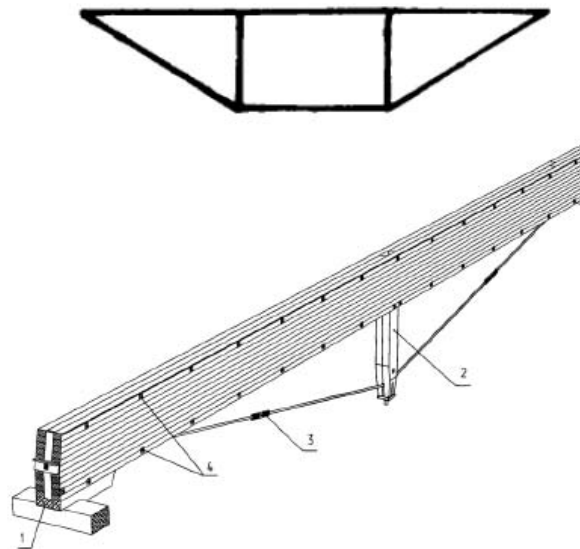

Optimal spans: 9 ... 15 m;
Height: 1/4 ... 1/8 from span.

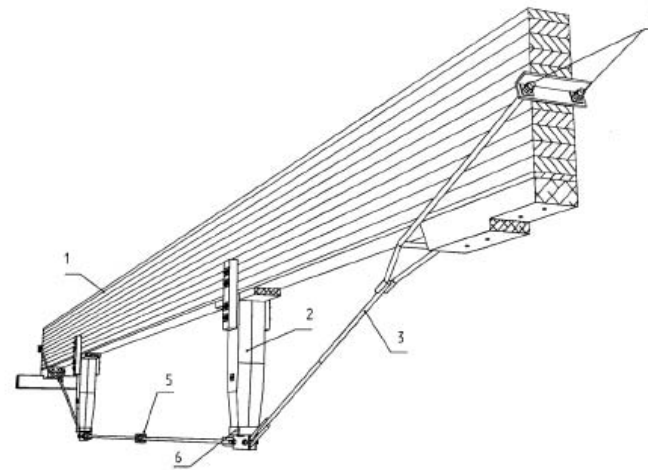

Main types of timber structures

Trusses

Triangular trusses with steel bottom chord

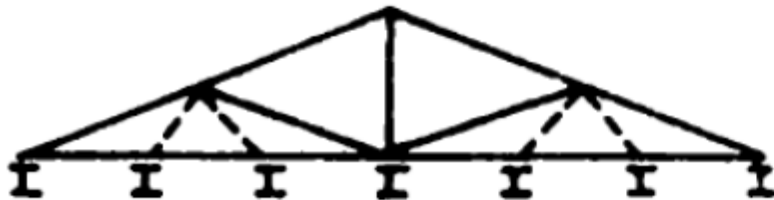

Optimal spans: 9 ... 15 m;
Height: $1/5$... $1/7$ from span.



Optimal spans: 9 ... 18 m;
Height: $1/5$... $1/7$ from span.

Main types of timber structures

Trusses

Trapezoid trusses with steel bottom chord

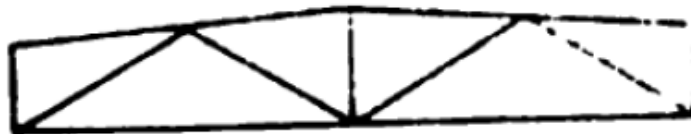

Optimal spans: 12 ... 24 m;
Height: $1/6$... $1/7$ from span.



Optimal spans: 24 ... 30 m;
Height: $1/6$... $1/7$ from span.



Optimal spans: 12 ... 24 m;
Height: $1/6$... $1/7$ from span.



Optimal spans: 24 ... 30 m;
Height: $1/6$... $1/7$ from span.

Scientific Seminar
Design of Timber Structures
By EN 1995-1-1
RTU, November 17, 2016

Main types of timber structures

Trusses

Polygonal Trusses with Glulam Top Chord and Steel Bottom Chord



Optimal spans: 12 m;
Height: $1/6 \dots 1/7$ from span.



Optimal spans: 15 m;
Height: $1/6 \dots 1/7$ from span.

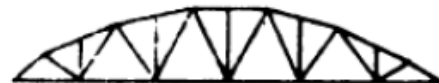

Optimal spans: 18 m;
Height: $1/6 \dots 1/7$ from span.

Scientific Seminar
Design of Timber Structures
By EN 1995-1-1
RTU, November 17, 2016

Main types of timber structures

Arches

Triangular Arches with three hinges

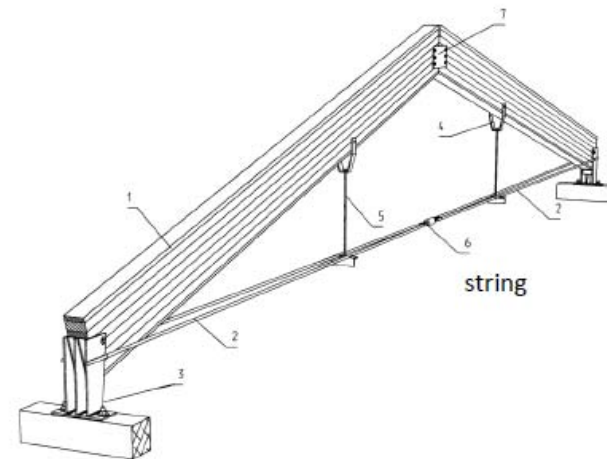
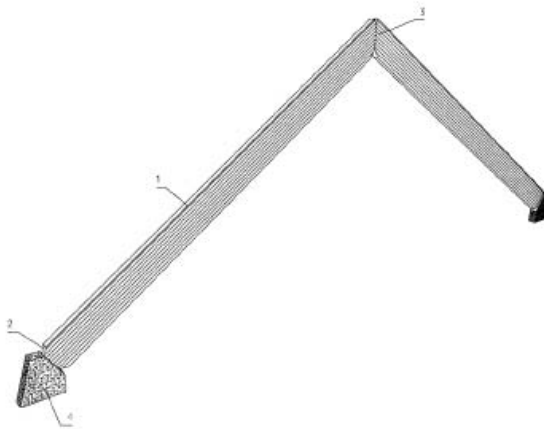

Optimal spans: 9 ... 18 m;
Height: $1/2$... $1/8$ from span.

Main types of timber structures

Arches

Arches with three hinges

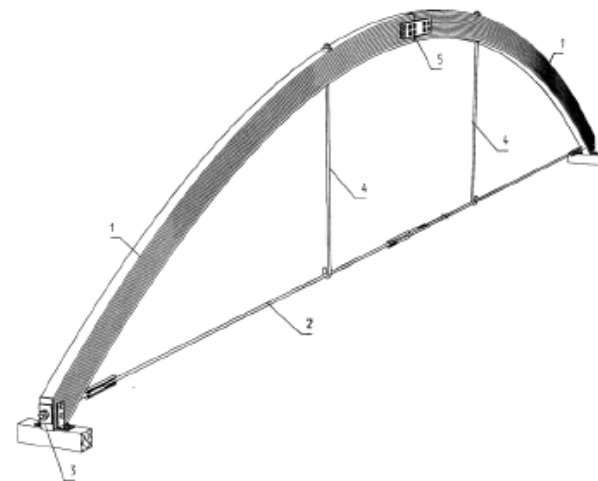

Optimal spans: 12 ... 60 m;
Height: $\frac{1}{6}$... $\frac{1}{8}$ from span.

Scientific Seminar
Design of Timber Structures
By EN 1995-1-1
RTU, November 17, 2016

Main types of timber structures

Arches

Equilateral arch

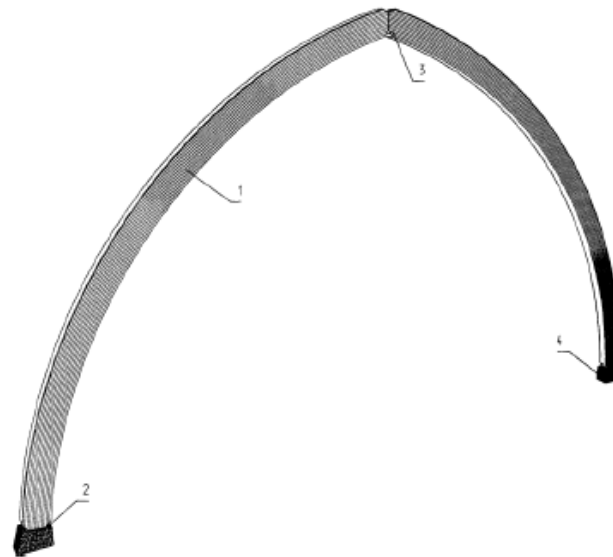

Height: $1/3 \dots 2/3$ from span.

Scientific Seminar
Design of Timber Structures
By EN 1995-1-1
RTU, November 17, 2016

Main types of timber structures

Frames

Three joint frames with stiff cornice joints

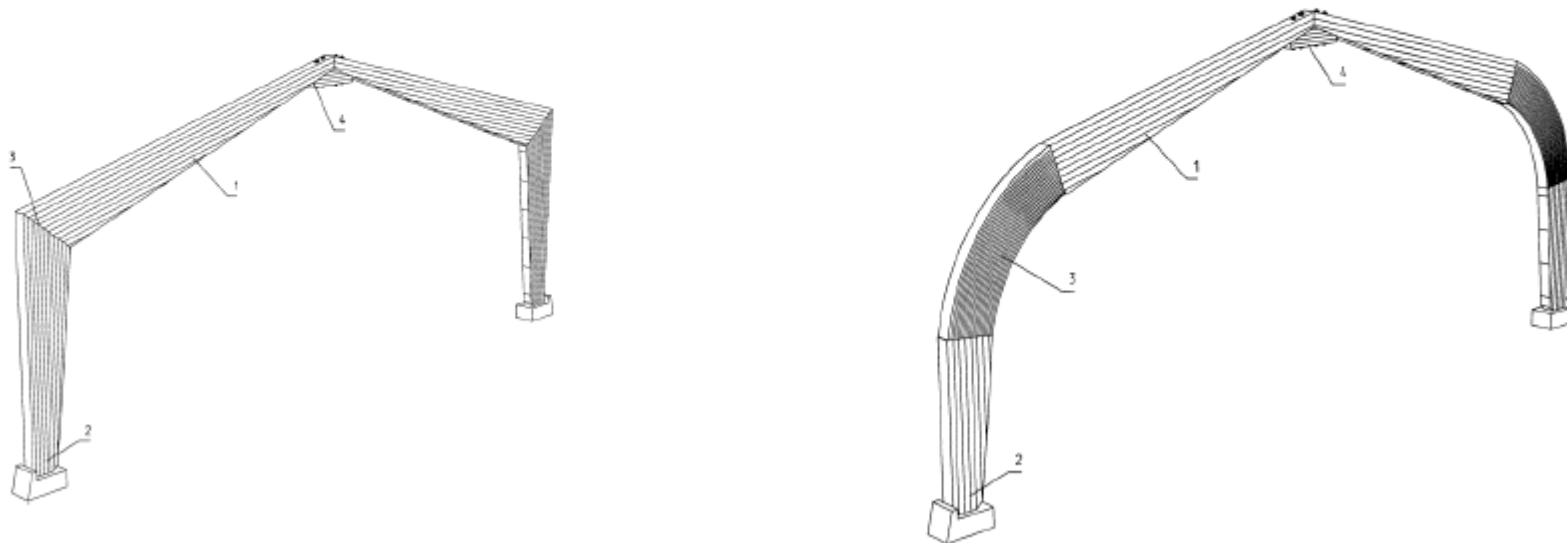

Scientific Seminar
Design of Timber Structures
By EN 1995-1-1
RTU, November 17, 2016

Main types of timber structures

Frames

Two joint frames with stiff base joints

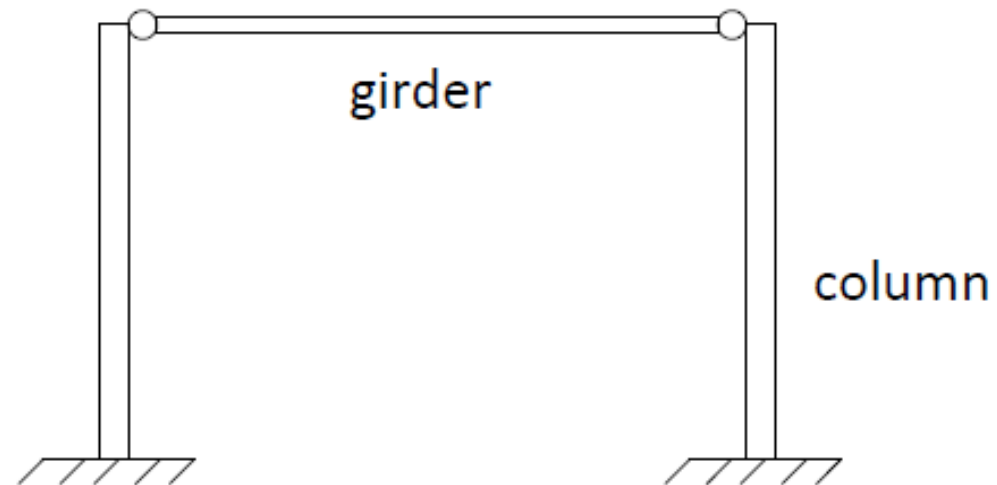

Scientific Seminar
Design of Timber Structures
By EN 1995-1-1
RTU, November 17, 2016

Main types of timber structures Spatial Structures

Cross Beam Structures

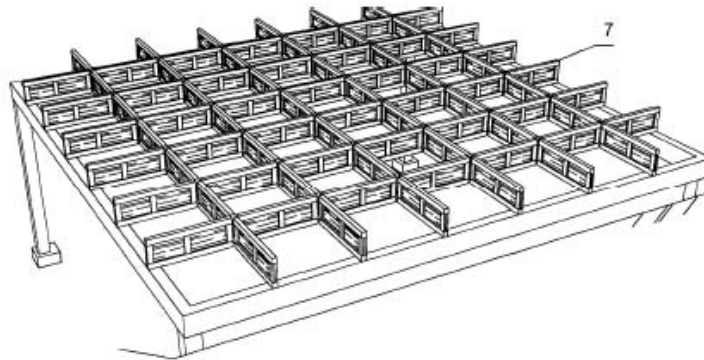

Crease Structures

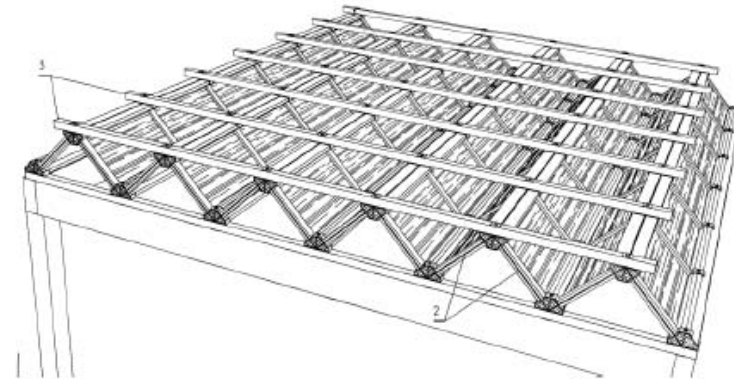

Scientific Seminar
Design of Timber Structures
By EN 1995-1-1
RTU, November 17, 2016

Main types of timber structures

Domes



Spans: 100 m;
Height: $\frac{1}{2}$... $\frac{1}{6}$ from diameter.

Scientific Seminar
Design of Timber Structures
By EN 1995-1-1
RTU, November 17, 2016



Bridge across river Sinne (Switzerland)



Faculty of architecture (Lyon)

Softwoods and hardwoods

Softwood characteristics

- Quick growth rate (trees can be felled after 30 years) resulting in low-density timber with relatively low strength.
- Generally poor durability qualities, unless treated with preservatives.
- Due to the speed of felling they are readily available and comparatively cheaper.

Pine, spruce, larch, cedar

Hardwood characteristics

- Hardwoods grow at a slower rate than softwoods, which generally results in a timber of high density and strength, which takes time to mature, over 100 years in some instances.
- There is less dependence on preservatives for durability qualities.
- Due to the time taken to mature and the transportation costs of hardwoods, as most are tropical, they tend to be expensive in comparison with softwoods.

Oak, ash, birch

Scientific Seminar
 Design of Timber Structures
 By EN 1995-1-1
 RTU, November 17, 2016

Mechanical Properties

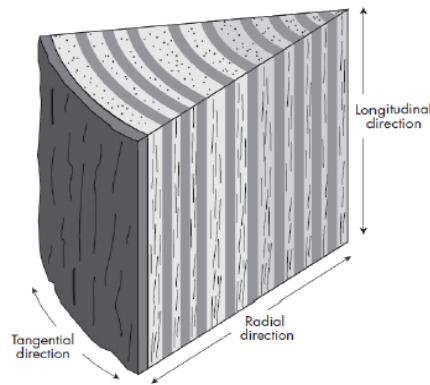

Soft wood strength classes:
 C14, C16, C18, C20, C22, C24, C27, C30,
 C35, C40, C45, C50;

Hard wood strength classes:
 D30, D35, D40, D50, D60, D70

Determined by:

Visual grading: knots, slope of grains, rate of
 growth, wane, resin pockets, distortion;

Machine grading: different tests.

Regulated by standards

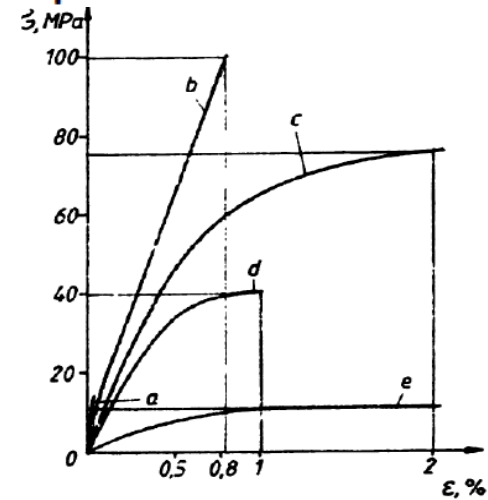

a – shear parallel to grain;
 b – tension parallel to grain;
 c – bending;
 d – compression parallel to grain;
 e – surface compression
 perpendicular to grain

Scientific Seminar
 Design of Timber Structures
 By EN 1995-1-1
 RTU, November 17, 2016

Mechanical Properties

Stress Condition	Symbol	Strength classes									
		C14	C16	C18	C20	C22	C24	C27	C30	C35	C40
Strength characteristic value, N/mm^2											
bending	$f_{m,k}$	14	16	18	20	22	24	27	30	35	40
tension parallel to grain	$f_{t,0,k}$	8	10	11	12	13	14	16	18	21	24
tension perp. to grain	$f_{t,90,k}$	0.4	0.5	0.5	0.5	0.5	0.5	0.6	0.6	0.6	0.6
compression parallel to grain	$f_{c,0,k}$	16	17	18	19	20	21	22	23	25	26
compression perp. to grain	$f_{c,90,k}$	2.0	2.2	2.2	2.3	2.4	2.5	2.6	2.7	2.8	2.9
shear	$f_{v,k}$	1.7	1.8	2	2.2	2.4	2.5	2.8	3	3.4	3.8
Modulus of Elasticity parallel to grain, kN/mm^2											
average value	$E_{0,mean}$	7	8	9	9.5	10	11	11,5	12	13	14
Modulus of Elasticity perpendicular to grain, kN/mm^2											
average value	$E_{90,mean}$	0.23	0.27	0.30	0.32	0.33	0.37	0.38	0.40	0.43	0.47
Shear Modulus, kN/mm^2											
average value	$G_{90,mean}$	0.44	0.50	0.56	0.59	0.63	0.69	0.72	0.75	0.81	0.88
Density kN/m^3											
average value	γ_{mean}	3,5	3,7	3,8	3,9	4,1	4,2	4,5	4,6	4,8	5,0

Scientific Seminar
Design of Timber Structures
By EN 1995-1-1
RTU, November 17, 2016

Limit State design

The limit state design philosophy, which was formulated for reinforced concrete design in Russia during the 1930s, achieves the objectives by considering two „types” of limit state under which a structure may become unfit for its intended purpose. They are:

the **Ultimate Limit State** in which the structure, or some part of it, is unsafe for its intended purpose, e.g. compressive, tensile, shear or flexural failure or instability leading to partial or total collapse;

the **Serviceability Limit State** in which a condition, e.g. deflection, vibration or cracking, occurs to an extent, which is unacceptable to the owner, occupier, client etc.

The basis of the approach is statistical and lies in assessing the probability of reaching a given limit state and deciding upon an acceptable level of that probability for design purposes. The method in most codes is based on the use of **characteristic values** and **partial safety factors**.

Scientific Seminar
Design of Timber Structures
By EN 1995-1-1
RTU, November 17, 2016

Partial Safety Factors

The use of **partial safety factors**, which are applied separately to individual parameters, enables the degree of risk for each one to be varied. This reflects the differing degrees of control which are possible in the manufacturing process of building structural materials/units (e.g. steel, concrete, timber, mortar and individual bricks) and construction process such as steel fabrication, pre-cast concrete, or building in masonry.

Scientific Seminar
Design of Timber Structures
By EN 1995-1-1
RTU, November 17, 2016

Characteristic Values

The use of **characteristic values** enables the statistical variability of various parameters such as materials strength, different load types, etc., to be incorporated in an assessment of the acceptable probability that the value of the parameter will be exceeded during the life of structure. The term **characteristic** in current design codes normally refers to a value of such magnitude that statistically for loads, there is a 5% probability of it being exceeded, whilst for strength, there is a 5% probability of the actual strength being less.

Scientific Seminar
 Design of Timber Structures
 By EN 1995-1-1
 RTU, November 17, 2016

Limit State Philosophy

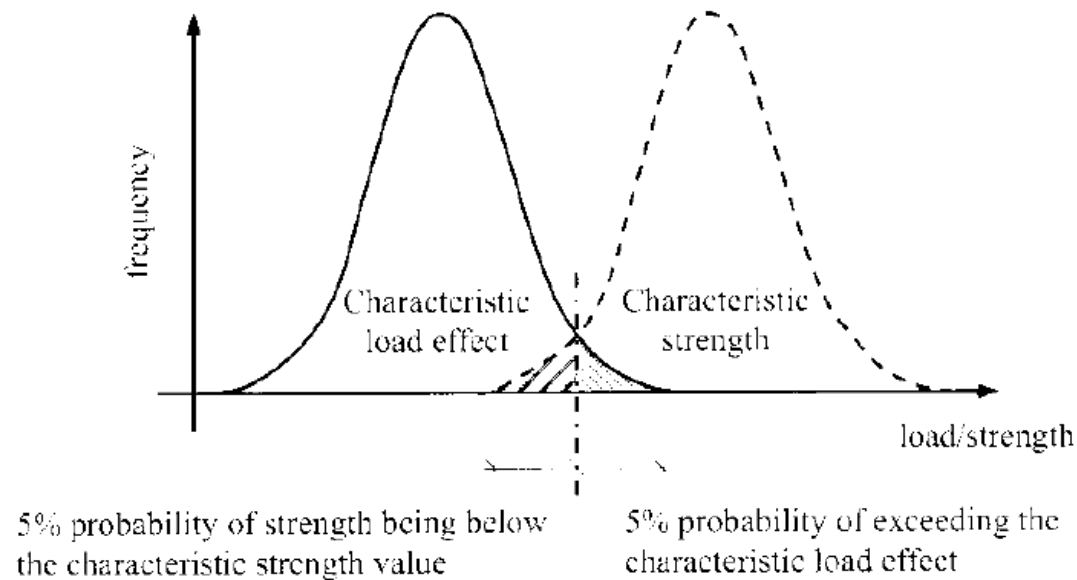

The shaded area represents the probability of failure, i.e. the level of design load effect, which can be expected to be exceeded by 5%, and the level of design strength which 5% of samples can be expected to fall below. The point of intersection of these two distribution curves represents the ultimate limit state, i.e. the design strength equals the design load effect.

Scientific Seminar
Design of Timber Structures
By EN 1995-1-1
RTU, November 17, 2016

Structural Design According to Eurocodes

The European Standards Organisation, **CEN**, is the umbrella organisation under which a set of common structural design standards (EC1, EC2, EC3, etc.) are being developed. The structural Eurocodes are the result of attempts to eliminate barriers to trade throughout the European Union. Separate codes exist for each structural material.

EN 1991 Eurocode 1 : Actions on structures

EN 1992 Eurocode 2 : Design of concrete structures

EN 1993 Eurocode 3 : Design of steel structures

EN 1994 Eurocode 4 : Design of composite steel and concrete structures

EN 1995 Eurocode 5 : Design of timber structures

EN 1996 Eurocode 6 : Design of masonry structures

EN 1997 Eurocode 7 : Geotechnical design

EN 1998 Eurocode 8 : Design of structures for earthquake resistance

EN 1999 Eurocode 9 : Design of aluminium structures

Scientific Seminar
Design of Timber Structures
By EN 1995-1-1
RTU, November 17, 2016

Basic requirements of Structural Design

A structure shall be designed to have adequate :

- structural resistance,
- serviceability,
- durability.

In the case of fire, the structural resistance shall be adequate for the required period of time.

Scientific Seminar
Design of Timber Structures
By EN 1995-1-1
RTU, November 17, 2016

EN1995-1-1 Scope and structure

- **Section 1:** General definitions, terminology
- **Section 2:** Basis of design: Timber specific supplement to EN1990
- **Section 3:** Material properties to be used for design
- **Section 4:** Durability concept
- **Section 5:** Basis of structural analysis
- **Section 6:** Ultimate limit state design principles
- **Section 7:** Serviceability limit states
- **Section 8:** Fasteners
- **Section 9:** Design of components and assemblies
- **Section 10:** Workmanship, structural detailing and control

Scientific Seminar
Design of Timber Structures
By EN 1995-1-1
RTU, November 17, 2016

Link of EN 1995-1-1 to EN1990 and EN1991

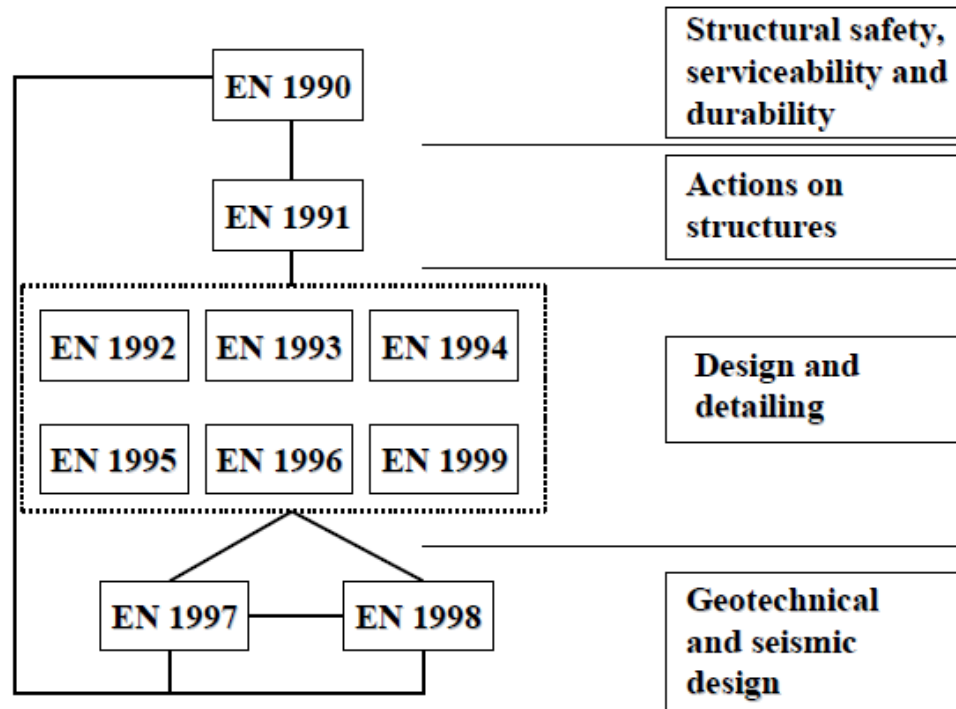

Scientific Seminar
Design of Timber Structures
By EN 1995-1-1
RTU, November 17, 2016

Design value of material properties X_d

$$X_d = k_{\text{mod}} \frac{X_k}{\gamma_M}$$

X_k – characteristic value of a strength property

γ_M – partial factor for a material property

k_{mod} – modification factor, taking into account duration of load and moisture content

Scientific Seminar
 Design of Timber Structures
 By EN 1995-1-1
 RTU, November 17, 2016

Strength classes - Characteristic values

		Softwood species											Hardwood species								
		C14	C16	C18	C20	C22	C24	C27	C30	C35	C40	C45	C50	D18	D24	D30	D35	D40	D50	D60	D70
Strength properties (in N/mm²)																					
Bending	$f_{m,k}$	14	16	18	20	22	24	27	30	35	40	45	50	18	24	30	35	40	50	60	70
Tension parallel	$f_{t,0,k}$	8	10	11	12	13	14	16	18	21	24	27	30	11	14	18	21	24	30	36	42
Tension perpendicular	$f_{t,90,k}$	0,4	0,4	0,4	0,4	0,4	0,4	0,4	0,4	0,4	0,4	0,4	0,4	0,6	0,6	0,6	0,6	0,6	0,6	0,6	0,6
Compression parallel	$f_{c,0,k}$	16	17	18	19	20	21	22	23	25	26	27	29	18	21	23	25	26	29	32	34
Compression perpendicular	$f_{c,90,k}$	2,0	2,2	2,2	2,3	2,4	2,5	2,6	2,7	2,8	2,9	3,1	3,2	7,5	7,8	8,0	8,1	8,3	9,3	10,5	13,5
Shear	$f_{v,k}$	3,0	3,2	3,4	3,6	3,8	4,0	4,0	4,0	4,0	4,0	4,0	4,0	3,4	4,0	4,0	4,0	4,0	4,0	4,5	5,0
Stiffness properties (in kN/mm²)																					
Mean modulus of elasticity parallel	$E_{0,mean}$	7	8	9	9,5	10	11	11,5	12	13	14	15	16	9,5	10	11	12	13	14	17	20
5 % modulus of elasticity parallel	$E_{0,05}$	4,7	5,4	6,0	6,4	6,7	7,4	7,7	8,0	8,7	9,4	10,0	10,7	8	8,5	9,2	10,1	10,9	11,8	14,3	16,8
Mean modulus of elasticity perpendicular	$E_{90,mean}$	0,23	0,27	0,30	0,32	0,33	0,37	0,38	0,40	0,43	0,47	0,50	0,53	0,63	0,67	0,73	0,80	0,86	0,93	1,13	1,33
Mean shear modulus	G_{mean}	0,44	0,5	0,56	0,59	0,63	0,69	0,72	0,75	0,81	0,88	0,94	1,00	0,59	0,62	0,69	0,75	0,81	0,88	1,06	1,25
Density (in kg/m³)																					
Density	ρ_k	290	310	320	330	340	350	370	380	400	420	440	460	475	485	530	540	550	620	700	900
Mean density	ρ_{mean}	350	370	380	390	410	420	450	460	480	500	520	550	570	580	640	650	660	750	840	1080

Indexes:

c – compression; v – shear (V – shear force); k – characteristic value;
 t – tension; 0 – parallel to grain; d – design value.
 m – bending (M - moment); 90 – perp. to grain;

Scientific Seminar
Design of Timber Structures
By EN 1995-1-1
RTU, November 17, 2016

EN1995-1-1 - Definition of axes

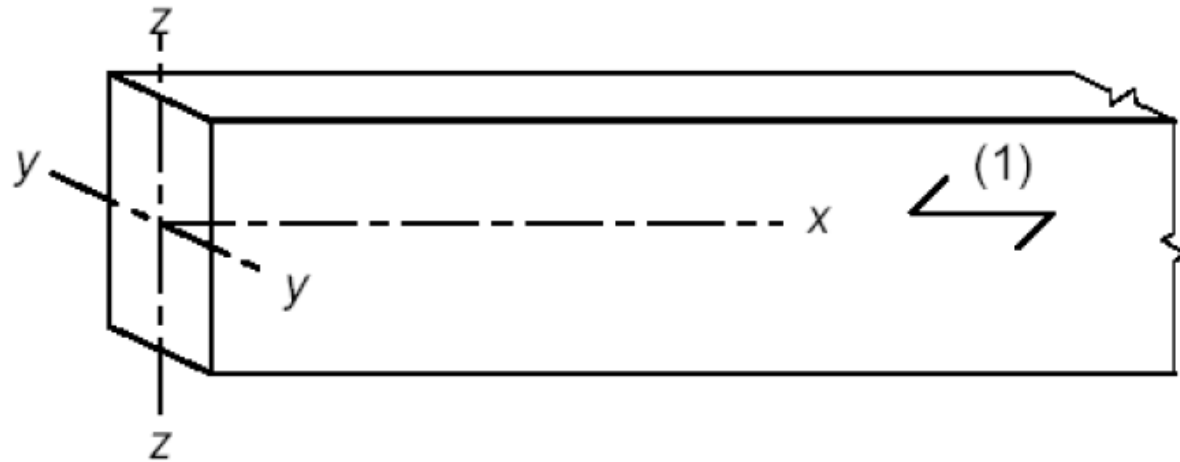

Partial safety factor γ_M

Fundamental combinations:	
Solid timber	1,3
Glued laminated timber	1,25
LVL, plywood, OSB,	1,2
Particleboards	1,3
Fibreboards, hard	1,3
Fibreboards, medium	1,3
Fibreboards, MDF	1,3
Fibreboards, soft	1,3
Connections	1,3
Punched metal plate fasteners	1,25
Accidental combinations	1,0

Recommended material safety factor $\gamma_M = 1,3$

Scientific Seminar
 Design of Timber Structures
 By EN 1995-1-1
 RTU, November 17, 2016

Strength modification factor k_{mod}

Material	Standard	Service class	Load-duration class				
			Permanent action	Long term action	Medium term action	Short term action	Instantaneous action
Solid timber	EN 14081-1	1	0,60	0,70	0,80	0,90	1,10
		2	0,60	0,70	0,80	0,90	1,10
		3	0,50	0,55	0,65	0,70	0,90
Glued laminated timber	EN 14080	1	0,60	0,70	0,80	0,90	1,10
		2	0,60	0,70	0,80	0,90	1,10
		3	0,50	0,55	0,65	0,70	0,90
LVL	EN 14374, EN 14279	1	0,60	0,70	0,80	0,90	1,10
		2	0,60	0,70	0,80	0,90	1,10
		3	0,50	0,55	0,65	0,70	0,90
Plywood	EN 636 Part 1, Part 2, Part 3 Part 2, Part 3 Part 3	1	0,60	0,70	0,80	0,90	1,10
		2	0,60	0,70	0,80	0,90	1,10
		3	0,50	0,55	0,65	0,70	0,90
OSB	EN 300 OSB/2 OSB/3, OSB/4 OSB/3, OSB/4	1	0,30	0,45	0,65	0,85	1,10
		1	0,40	0,50	0,70	0,90	1,10
		2	0,30	0,40	0,55	0,70	0,90
Particle-board	EN 312 Part 4, Part 5 Part 5 Part 6, Part 7 Part 7	1	0,30	0,45	0,65	0,85	1,10
		2	0,20	0,30	0,45	0,60	0,80
		1	0,40	0,50	0,70	0,90	1,10
		2	0,30	0,40	0,55	0,70	0,90
Fibreboard, hard	EN 622-2 HB.LA, HB.HLA 1 or 2 HB.HLA1 or 2	1	0,30	0,45	0,65	0,85	1,10
		2	0,20	0,30	0,45	0,60	0,80
Fibreboard, medium	EN 622-3 MBH.LA1 or 2 MBH.HLS1 or 2 MBH.HLS1 or 2	1	0,20	0,40	0,60	0,80	1,10
		1	0,20	0,40	0,60	0,80	1,10
		2	–	–	–	0,45	0,80
Fibreboard, MDF	EN 622-5 MDF.LA, MDF.HLS MDF.HLS	1	0,20	0,40	0,60	0,80	1,10
		2	–	–	–	0,45	0,80

Scientific Seminar
Design of Timber Structures
By EN 1995-1-1
RTU, November 17, 2016

Load duration classes and examples

Load-duration class	Order of accumulated duration of characteristic load	Examples of loading
Permanent	more than 10 years	self-weight
Long-term	6 months – 10 years	storage
Medium-term	1 week – 6 months	imposed floor load, snow
Short-term	less than one week	snow, wind
Instantaneous		wind, accidental load

Scientific Seminar
Design of Timber Structures
By EN 1995-1-1
RTU, November 17, 2016

Service Classes

Service class 1 is characterised by a moisture content in the materials corresponding to a temperature of 20°C and the relative humidity of the surrounding air only exceeding 65 % for a few weeks per year.

In service class 1 the average moisture content in most softwoods will not exceed 12 %.



Service Classes

Service class 2 is characterised by a moisture content in the materials corresponding to a temperature of 20°C and the relative humidity of the surrounding air only exceeding 85 % for a few weeks per year.

In service class 2 the average moisture content in most softwoods will not exceed 20 %.



Scientific Seminar
Design of Timber Structures
By EN 1995-1-1
RTU, November 17, 2016

Service Classes

Service class 3 is characterised by climatic conditions leading to higher moisture contents than in service class 2.



Serviceability limit states

Beam example

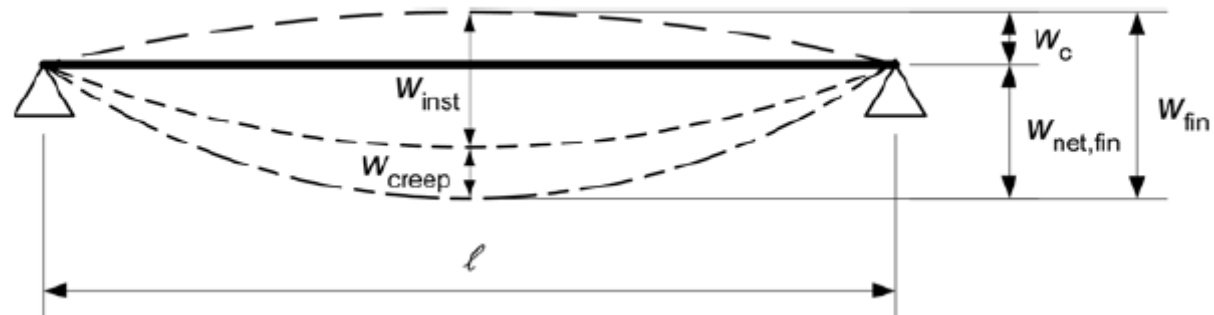

- w_c is the precamber (if applied);
- w_{inst} is the instantaneous deflection;
- w_{creep} is the creep deflection;
- w_{fin} is the final deflection;
- $w_{net,fin}$ is the net final deflection.

$$w_{net,fin} = w_{inst} + w_{creep} - w_c = w_{fin} - w_c$$

Serviceability limit states

Beam example

Examples of limiting values for deflections of beams

	w_{inst}	$w_{net,fin}$	w_{fin}
Beam on two supports	$l/300$ to $l/500$	$l/250$ to $l/350$	$l/150$ to $l/300$
Cantilevering beams	$l/150$ to $l/250$	$l/125$ to $l/175$	$l/75$ to $l/150$

Scientific Seminar
 Design of Timber Structures
 By EN 1995-1-1
 RTU, November 17, 2016

Deformation modification factor k_{def}

Material	Standard	Service class		
		1	2	3
Solid timber	EN 14081-1	0,60	0,80	2,00
Glued Laminated timber	EN 14080	0,60	0,80	2,00
LVL	EN 14374, EN 14279	0,60	0,80	2,00
Plywood	EN 636			
	Part 1	0,80	–	–
	Part 2	0,80	1,00	–
	Part 3	0,80	1,00	2,50
OSB	EN 300			
	OSB/2	2,25	–	–
	OSB/3, OSB/4	1,50	2,25	–
Particleboard	EN 312			
	Part 4	2,25	–	–
	Part 5	2,25	3,00	–
	Part 6	1,50	–	–
	Part 7	1,50	2,25	–
Fibreboard, hard	EN 622-2			
	HB.LA	2,25	–	–
	HB.HLA1, HB.HLA2	2,25	3,00	–
Fibreboard, medium	EN 622-3			
	MBH.LA1, MBH.LA2	3,00	–	–
	MBH.HLS1, MBH.HLS2	3,00	4,00	–
Fibreboard, MDF	EN 622-5			
	MDF.LA	2,25	–	–
	MDF.HLS	2,25	3,00	–

Axially loaded timber elements

Tension parallel to the grain

$$\sigma_{t,0,d} \leq f_{t,0,d}$$

$\sigma_{t,0,d}$ is the design tensile stress along the grain;
 $f_{t,0,d}$ is the design tensile strength along the grain.

Effective cross-section area

Effective area A_{ef} of tensioned members is calculated by combining of all weakenings (holes), which are situated on the part of element with length (to both sides from the design section), which is $\frac{1}{2}$ of allowed minimal distance between connectors. For bolts: $5d$.

The weakenings can be ignored if:

- weakenings are caused by nails and screws with diameter less than 6 mm and if they are worked into without predrilling.
- weakenings are situated in the compressed zone and are filled with material with larger stiffness characteristics, than wood.
- for stability calculations, if weakenings not cause external grains.

Tension perpendicular to the grain

The effect of member size shall be taken into account.

Solid timber:
$$\sigma_{t,90,d} \leq f_{t,90,d}$$

Glued timber:
$$\sigma_{t,90,d} \leq f_{t,90,d} \left(V_0 / V \right)^{0.2}$$

V_0 – base volume in tension, for glued timber $V_0 = 0.01 \text{ m}^3$;

V – actual volume of stressed timber perpendicular to the grains

Compression parallel to the grain

$$\sigma_{c,0,d} \leq f_{c,0,d}$$

- $\sigma_{c,0,d}$ is the design compressive stress along the grain;
 $f_{c,0,d}$ is the design compressive strength along the grain.

Compression perpendicular to the grain

$$\sigma_{c,90,d} \leq k_{c,90} f_{c,90,d}$$

- $\sigma_{c,90,d}$ is the design compressive stress in the contact area perpendicular to the grain;
 $f_{c,90,d}$ is the design compressive strength perpendicular to the grain;
 $k_{c,90}$ is a factor taking into account the load configuration, possibility of splitting and degree of compressive deformation.

Stability of members

Stability shall be verified using the characteristic properties, e.g. $E_{0,05}$

The relative slenderness ratios:

$$\lambda_{rel,y} = \frac{\lambda_y}{\pi} \sqrt{\frac{f_{c,0,k}}{E_{0,05}}} \qquad \lambda_{rel,z} = \frac{\lambda_z}{\pi} \sqrt{\frac{f_{c,0,k}}{E_{0,05}}}$$

λ_y and $\lambda_{rel,y}$ - slenderness ratios corresponding to bending about the y-axis (deflection in the z-direction);

If both $\lambda_{rel,z} \leq 0,3$ and $\lambda_{rel,y} \leq 0,3$, stability can not be checked.

Rectangular:

$$\lambda_y = \frac{l_{ef,y}}{i_y} = \frac{l_{ef,y}}{h / \sqrt{12}}$$

$$\lambda_z = \frac{l_{ef,z}}{i_z} = \frac{l_{ef,z}}{b / \sqrt{12}}$$

Circle:

$$\lambda = \frac{l_{ef}}{i} = \frac{l_{ef}}{D / 4}$$

Stability of members

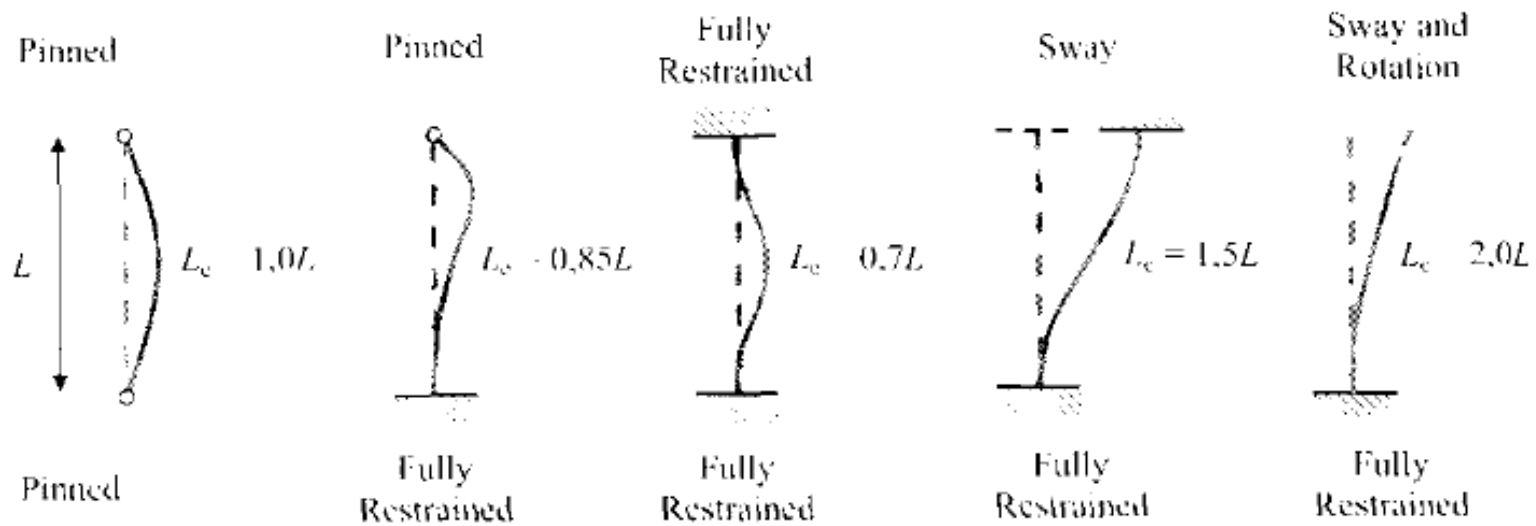

Stability of members

$$\frac{\sigma_{c,0,d}}{k_{c,y} f_{c,0,d}} \leq 1 \quad \frac{\sigma_{c,0,d}}{k_{c,z} f_{c,0,d}} \leq 1$$

$$k_{c,y} = \frac{1}{k_y + \sqrt{k_y^2 - \lambda_{rel,y}^2}} \quad k_{c,z} = \frac{1}{k_z + \sqrt{k_z^2 - \lambda_{rel,z}^2}}$$

$$k_y = 0,5 \left(1 + \beta_c (\lambda_{rel,y} - 0,3) + \lambda_{rel,y}^2 \right)$$

$$k_z = 0,5 \left(1 + \beta_c (\lambda_{rel,z} - 0,3) + \lambda_{rel,z}^2 \right)$$

$$\beta_c = \begin{cases} 0,2 & \text{for solid timber} \\ 0,1 & \text{for glued laminated timber and LVL} \end{cases}$$

Timber elements subjected to flexure

Flexural members are those elements in a structure that are subjected to bending, and several types and forms of such members are used in timber construction. Typical examples are solid section rectangular beams, floor joists, rafters and purlins. Other examples include glulam beams and composites (thin webbed beams and thin flanged beams).

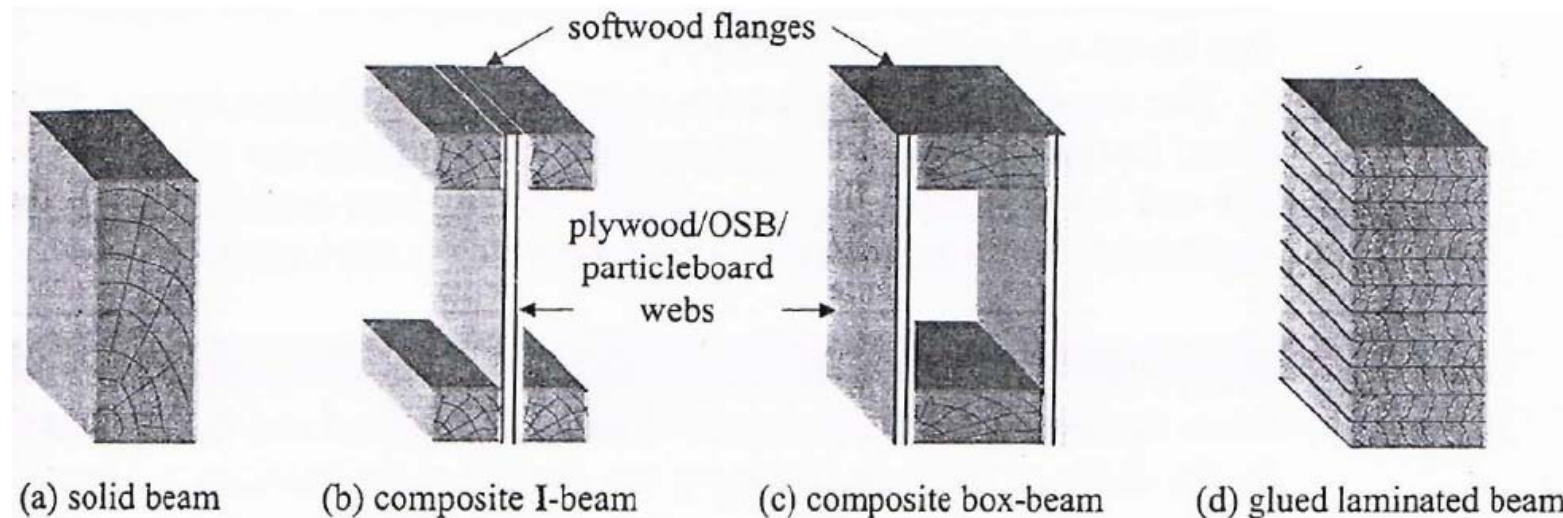

Scientific Seminar
Design of Timber Structures
By EN 1995-1-1
RTU, November 17, 2016

Timber elements subjected to flexure

The principal considerations in the design of all beams and floor systems comprise both ultimate and serviceability limit states as follows:

Ultimate Limit States

bending;
shear;
torsion;
bearing;
lateral torsional stability.

Serviceability Limit States

deflection;
vibration.

Span

The design span, i.e. the effective span of the beam, will be the clear span plus half the bearing length at each end.

For **solid timber beams and built-up flooring beams** required bearing length is **50 mm**.
For **built-up beams with spans up to 12 m** required bearing length is **100 mm**.

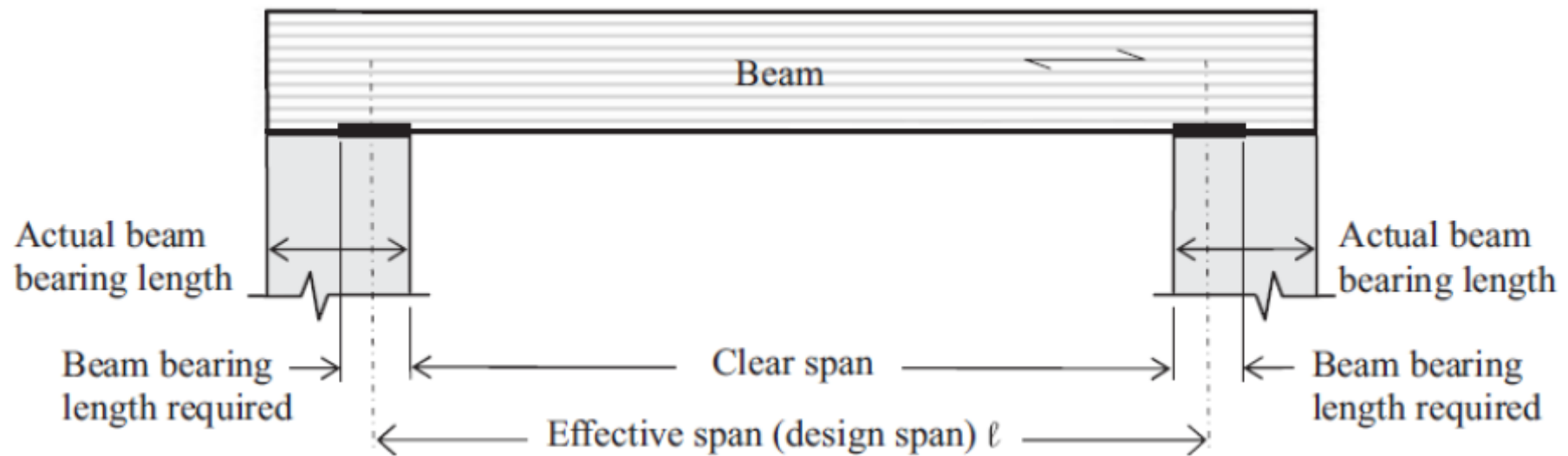

Ultimate limit state

Strength according to maximal normal stresses

$$\frac{\sigma_{m,y,d}}{f_{m,y,d}} + k_m \frac{\sigma_{m,z,d}}{f_{m,z,d}} \leq 1$$

$$k_m \frac{\sigma_{m,y,d}}{f_{m,y,d}} + \frac{\sigma_{m,z,d}}{f_{m,z,d}} \leq 1$$

$\sigma_{m,y,d}$ and $\sigma_{m,z,d}$ – the design bending stresses about the principal axes

$f_{m,y,d}$ and $f_{m,z,d}$ – the corresponding design bending strengths

k_m – factor, that makes allowance for re-distribution of stresses and the effect of inhomogeneities of the material in a cross-section

Ultimate limit state

Strength according to maximal shear stresses

For shear with a stress component parallel to the grain as well as for shear with both stress components perpendicular to the grain the following expression shall be satisfied:

$$\tau_d \leq f_{v,d}$$

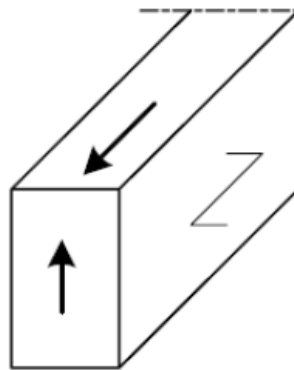

Member with a shear stress component parallel to the grain

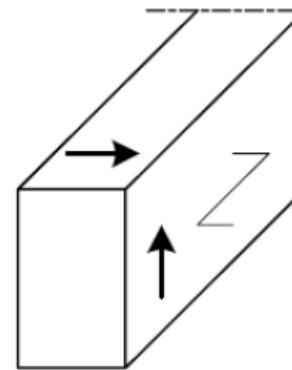

Member with both stress components perpendicular to the grain

Ultimate limit state

Strength according to torsion stresses

The following expression shall be satisfied:

$$\tau_{\text{tor,d}} \leq k_{\text{shape}} f_{\text{v,d}}$$

$$k_{\text{shape}} = \begin{cases} 1,2 & \text{for a circular cross section} \\ \min \begin{cases} 1+0,15 \frac{h}{b} \\ 2,0 \end{cases} & \text{for a rectangular cross section} \end{cases}$$

$\tau_{\text{tor,d}}$ is the design torsional stress;

$f_{\text{v,d}}$ is the design shear strength;

k_{shape} is a factor depending on the shape of the cross-section;

h is the larger cross-sectional dimension;

b is the smaller cross-sectional dimension.

Torsional stress

Circle cross-section: $\tau_{tor} = \frac{T}{\pi r^2}$ Rectangular cross-section: $\tau_{tor} = \frac{T}{\alpha h b^2}$

T – torsional moment;
 r – radius of cross-section;
 $h \geq b$;
 α – coefficient.

h/b	1,00	1,50	1,75	2,00	2,50	3,00	4,00	6,00	8,00	10,0	∞
α	0,208	0,231	0,239	0,246	0,258	0,267	0,282	0,299	0,307	0,313	0,333

Scientific Seminar
Design of Timber Structures
By EN 1995-1-1
RTU, November 17, 2016

Bearing

The behavior of timber under the action of concentrated loads, e.g. at position of support, is complex and influenced by both the length and locations of bearing. The design compressive strength perpendicular to the grain $f_{c,90,d}$ is used to determine the suitability of the bearing strength.

Ultimate limit state

Lateral Stability

The stresses should satisfy the following expression:

$$\sigma_{m,d} \leq k_{crit} f_{m,d}$$

$\sigma_{m,d}$ – is the design bending stress;

$f_{m,d}$ – is the design bending strength;

k_{crit} – is a factor which takes into account the reduced bending strength due to lateral buckling.

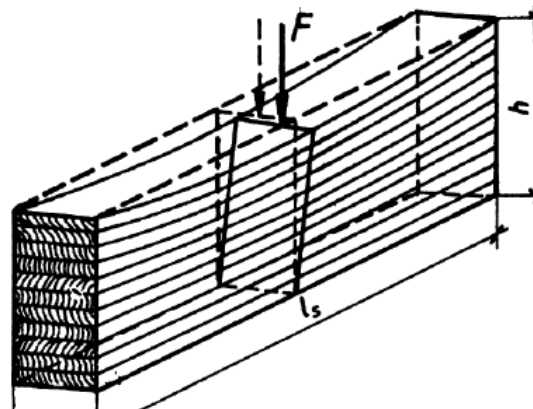

Ultimate limit state Lateral Stability

$$k_{\text{crit}} = \begin{cases} 1 & \text{for } \lambda_{\text{rel,m}} \leq 0,75 \\ 1,56 - 0,75\lambda_{\text{rel,m}} & \text{for } 0,75 < \lambda_{\text{rel,m}} \leq 1,4 \\ \frac{1}{\lambda_{\text{rel,m}}^2} & \text{for } 1,4 < \lambda_{\text{rel,m}} \end{cases}$$

The relative slenderness for bending: The critical bending stress should:

$$\lambda_{\text{rel,m}} = \sqrt{\frac{f_{\text{m,k}}}{\sigma_{\text{m,crit}}}} \qquad \sigma_{\text{m,crit}} = \frac{0,78b^2}{hl_{\text{ef}}} E_{0,05}$$

$E_{0,05}$ – is the fifth percentile value of modulus of elasticity parallel to grain;
 b – is the width of the beam;
 h – is the depth of the beam;
 l_{ef} – is the effective length of the beam, depending on the support conditions and the load configuration

Ultimate limit state
Lateral Stability
Effective length as a ratio of the span

Beam type	Loading type	l_{ef}/l^a
Simply supported	Constant moment	1,0
	Uniformly distributed load	0,9
	Concentrated force at the middle of the span	0,8
Cantilever	Uniformly distributed load	0,5
	Concentrated force at the free end	0,8
^a The ratio between the effective length l_{ef} and the span l is valid for a beam with torsionally restrained supports and loaded at the centre of gravity. If the load is applied at the compression edge of the beam, l_{ef} should be increased by $2h$ and may be decreased by $0,5h$ for a load at the tension edge of the beam.		



Scientific Seminar
Design of Timber Structures
By EN 1995-1-1
RTU, November 17, 2016

Experimental verification of design procedure for elements from cross-laminated timber

K Buka-Vaivade, D Serdjuks, V Goremikins, A Vilguts, L Pakrastins

Main advantages of CLT

- Mechanical properties comparable with steel and reinforced concrete;
- Shorter manufacturing and construction time;
- CLT is suitable for structural elements subjected to flexure with spans from 4 to 9 m;
- CLT is suitable for high (up to 30 floors) and middle raised buildings;
- Reduced CO² emissions.

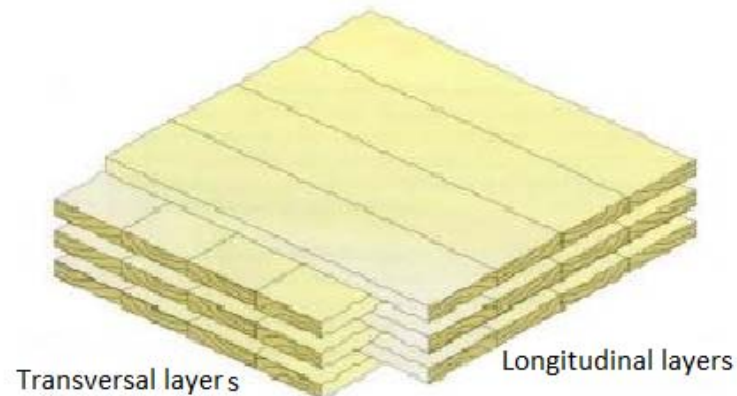



Scientific Seminar
Design of Timber Structures
By EN 1995-1-1
RTU, November 17, 2016

Aim of the work

The aim of the current work is a comparison of the existing methods for the designing of CLT load-bearing elements, subjected to flexure and choice of the method, which is characterized by the less workability and enough precision. All the considered methods must be verified by the FEM and laboratory experiment. The design procedure for design realization by the selected method must be explained.

Design methods of CLT elements subjected to flexure

The **gamma method** was developed by Professor Karl Möhler. Initially it was used for the designing of composite beams with T, I or closed box-type cross-sections.

Consumptions

- 1) The parts of the beams cross-sections are joined together by the compliant bonds;
- 2) Material is working in the elastic stage.

Designation of the layers of CLT plate

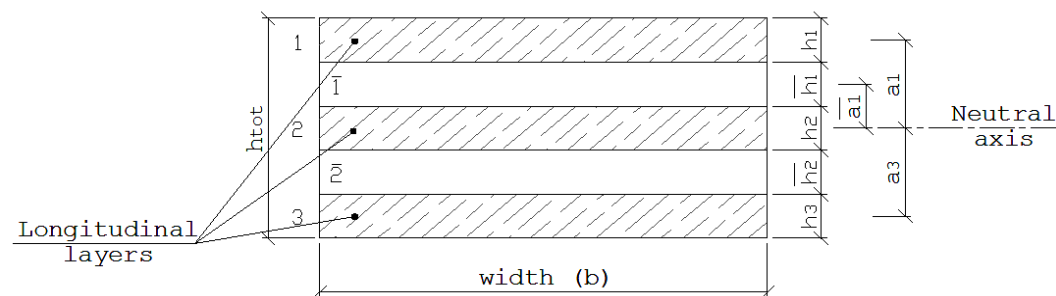

h_{tot} – total thickness of the plate; h_i – thickness of the i -th longitudinal layer; \hat{h}_i – thickness of the i -th transversal layer; b – width of the plate; a_i – distance from the neutral axis of the whole plate to the neutral axis of separate layer

Scientific Seminar
Design of Timber Structures
By EN 1995-1-1
RTU, November 17, 2016

Design methods of CLT elements subjected to flexure

Gamma method

The effective stiffness $(EI)_{ef}$ is a major parameter which has influence at the elements behaviour. It can be found by the following equation:

$$(EI)_{ef} = \sum_{i=1}^n (E_i \cdot I_i + \gamma_i \cdot E_i \cdot A_i \cdot a_i^2)$$

Where E_i – mean value of modulus of elasticity of separate board material in fiber direction; I_i – moment of inertia of the separate layer relative to its own main axis; a_i – distance from the middle plane of the whole cross-section to the middle plane of the separate layer; A_i – area of cross-section of the separate layer; γ_i – reduction factors, which takes in to account compliance of the bonds.

Design methods of CLT elements subjected to flexure Gamma method

The factors γ_i can be determined by the following equations in case of the plate, which consists from the five layers:

$$\gamma_1 = \frac{1}{1 + \frac{\pi^2 \cdot E_1 \cdot A_1 \cdot \bar{h}_1}{L^2 \cdot G_R \cdot b}}, \quad \gamma_2 = 1, \quad \gamma_3 = \frac{1}{1 + \frac{\pi^2 \cdot E_3 \cdot A_3 \cdot \bar{h}_2}{L^2 \cdot G_R \cdot b}}$$

Where L – span of the slab; G_R – shear modulus of board material perpendicular to fiber direction

Design methods of CLT elements subjected to flexure

K - method

The composite method (K-method) was developed by German scientists Hans Joachim Blass and Peter Fellmoser. This method initially was oriented at the design of plywood members, which are subjected to flexure.

Consumptions

- 1) All layers of the slab must be taken into account;
- 2) Span to height ratio of the slabs must not be less than 30, so as shear deformations are not taken into account;
- 3) Strength and stiffness of the layers must be determined using the factor k_i , which depends from the scheme of loading and structure of the panel.
- 4) The effective stiffness $(EI)_{ef}$ of the slab is determined with taking into account of all it layers.

Design methods of CLT elements subjected to flexure

Method of shear analogy

The method of shear analogy is considered as one of the most precise method for analyze of CLT plates so as elastic and shear modulus of all the layers are taken into account. The method of shear analogy was developed by German scientist Heinrich Kreuzinger. The slab is divided at two virtual beams, A and B, which are joined together by the immovable joints so that the deformations of the both beams are coinciding.

Model of the CLT slab by the method of shear analogy

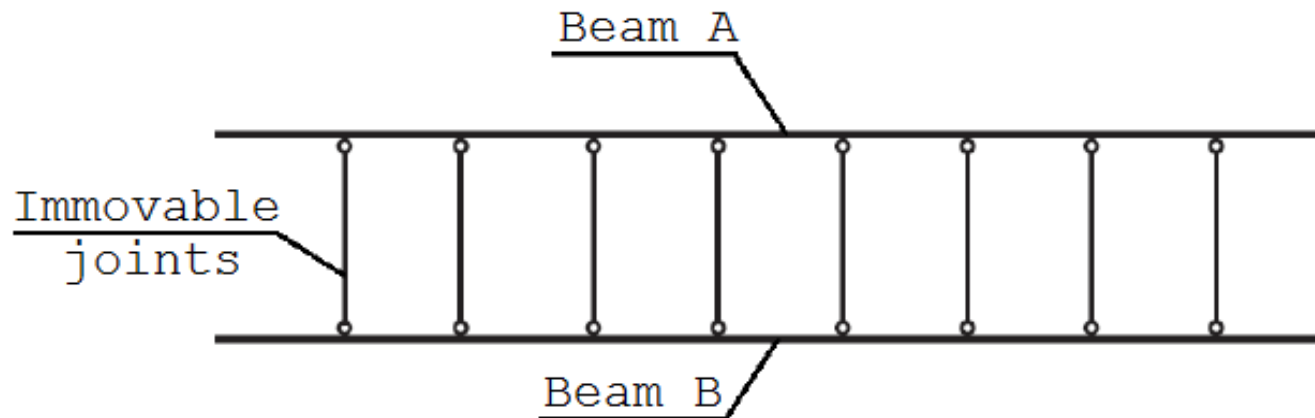

Design methods of CLT elements subjected to flexure

Method of shear analogy

The beam A is characterized by the infinitely big shear stiffness and its bending stiffness $(EI)_A$ is determined as a sum of the bending stiffness of separate layers relatively their own neutral axis. The total bending stiffness of the CLT slab $(EI)_{ef}$ is determined by the following equation:

$$(EI)_{ef} = (EI)_A + (EI)_B = \sum_{i=1}^n E_i \cdot I_i + \sum_{i=1}^n E_i \cdot A_i \cdot z_i^2$$

Where $(EI)_B$ is the bending stiffness of the beam B; z_i – the distance between the neutral axis of the i -th layer and neutral axis of the whole slab.

Scientific Seminar
Design of Timber Structures
By EN 1995-1-1
RTU, November 17, 2016

Design methods of CLT elements subjected to flexure

Short description of design procedure for transformed sections method

Transformed method is characterized by the simplified design procedure in comparison with the methods, which were mentioned above. Transformed cross-section method is joined with the replacement of real cross-section of element by the equivalent transformed cross-section.

Checks of ultimate limit state (ULS)

$$\sigma_{max,d} \leq f_{m,d}$$

$$\tau_{max,d} \leq f_{V,R,d}$$

Checks of serviceability limit state (SLS)

$$w_{fin} \leq \delta_{max}$$

Where w_{fin} is the final deflection of CLT slab; δ_{max} is the maximum available value for the final deflection of CLT plate, which is limited as a 1/300 part of the span.

Verification of transformed section method (TSM) by experiment and FEM

Eight CLT plates with the length and width equal to 2 and 0.35m, correspondingly and thickness of 60 mm were considered. All plates were formed by three layers of boards. Thicknesses of external and internal layers of boards are equal to 20 mm. Pine wood with strength class C24 was chosen as a base material. Dimensions of the board's cross-sections for outer and middle layers were equal to 20x50mm. The value of total vertical load change within the limits from 1 to 7 kN with the step equal to 1.0 kN.

Design scheme and measuring devices placement for CLT plates in four point bending

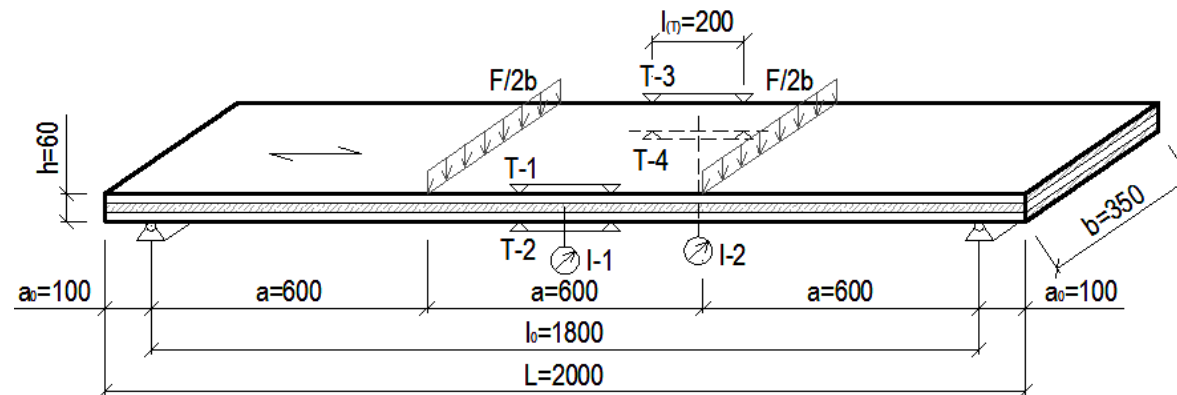

Maximum available value for the final deflection of CLT plate is limited as a 1/300 part of the span.

Verification of transformed section method (TSM) by experiment and FEM

The results, which were obtained for the considered CLT plate by the K-method, gamma method, shear analogy method and transformed section method, experiment and software RFEM 5.0 are shown in the figure.

The strain in the edge fibers of outer layers as a function from the vertical load's intensity

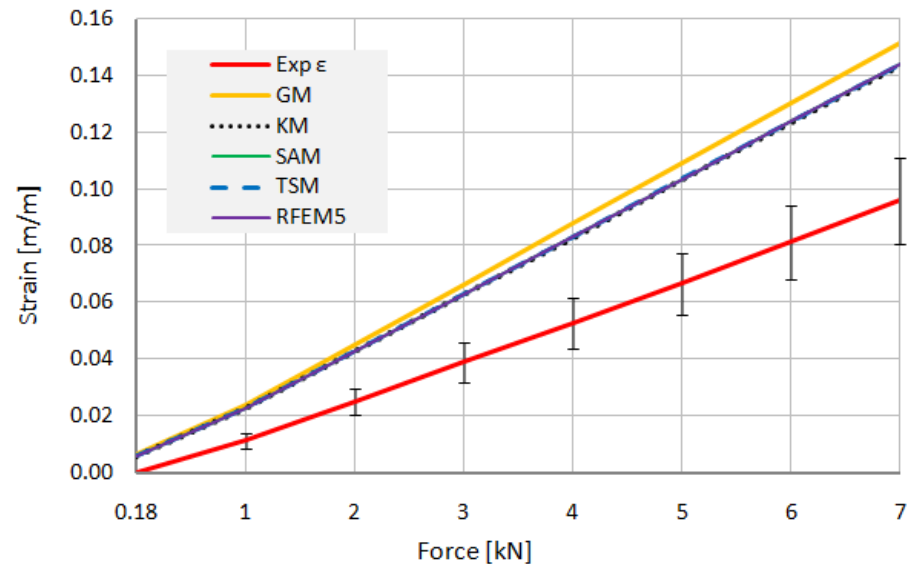

Verification of transformed section method (TSM) by experiment and FEM

The dependence of maximum vertical displacements in the middle of the span of CLT plates as a function from the load's intensity

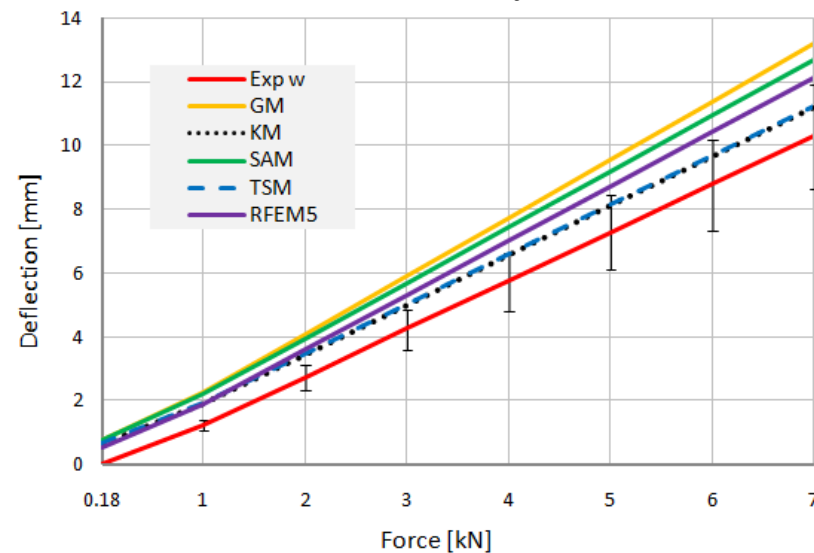

Material properties used for CLT plate calculation are following: mean modulus of elasticity $E_{0,mean} = 11$ GPa, $E_{90,mean} = 0.37$ MPa; the 5% fractile and mean bending strength $f_{m,k,0.05} = 24$ MPa, $f_{m,k,mean} = 35.8$ MPa.

Benchmark study of transformed section method (TSM)

The additional benchmark study was carried out to check the transformed section method for behaviour prediction of CLT plate under different loading type. One of the eight CLT plates was experimentally tested in three point bending up to the failure.

Design scheme and measuring devices placement for CLT plates in three point bending

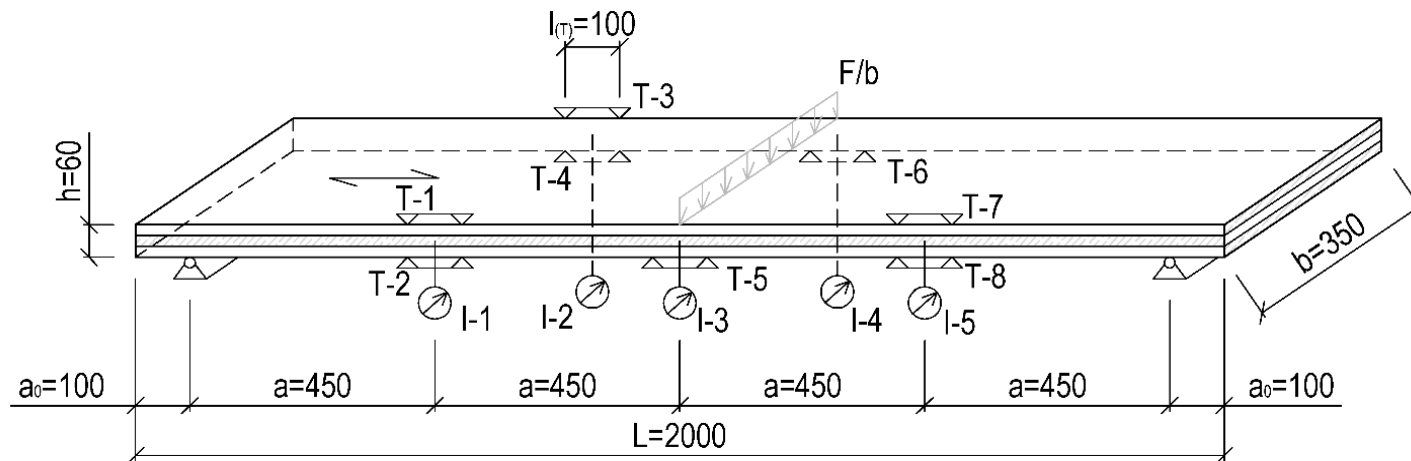

Scientific Seminar
Design of Timber Structures
By EN 1995-1-1
RTU, November 17, 2016

Benchmark study of transformed section method (TSM)

Plate under loading nearly collapse stage



Benchmark study of transformed section method (TSM)

Dependence of force on strain

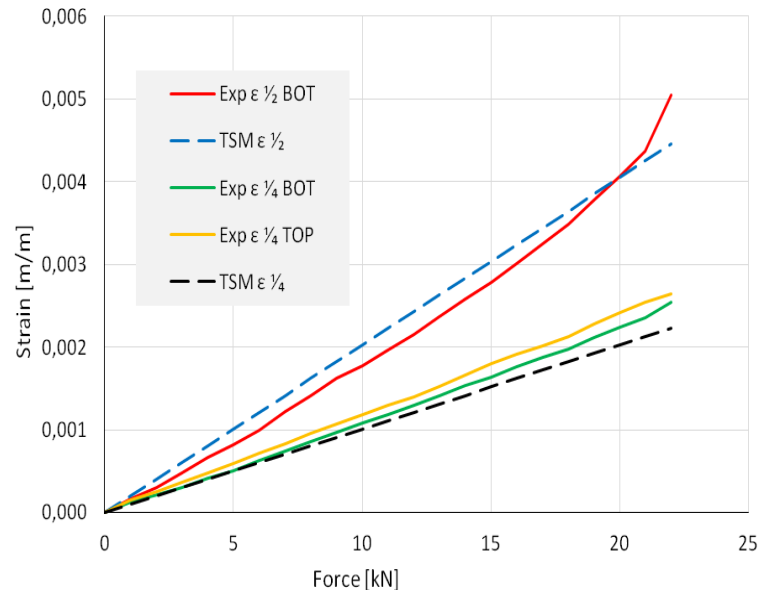

Dependence of force on deflection

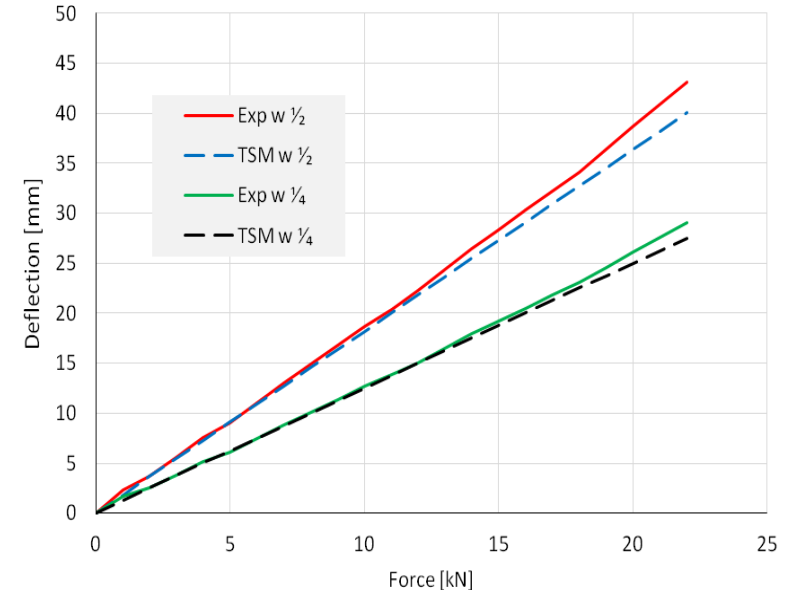

Scientific Seminar
Design of Timber Structures
By EN 1995-1-1
RTU, November 17, 2016

Benchmark study of transformed section method (TSM)

Collapse of CLT slab





Scientific Seminar
Design of Timber Structures
By EN 1995-1-1
RTU, November 17, 2016

Conclusions

The design procedure for the elements from cross-laminated timber was verified. K-method, gamma method, shear analogy method and transformed section method were compared analytically and by the experiment for behaviour prediction of statically loaded CLT panels in cases of three and four point bending. The differences between the maximum vertical displacements in the middle of the span of CLT plates obtained by the K-method, gamma method, shear analogy method, transformed section method, software RFEM 5.0 and experiment were equal to 3.30, 13.90, 9.50, 3.30 and 6.00%, correspondingly.

The additional benchmark study was carried out to check the transformed section method for behaviour prediction of CLT plate under the three point bending up to the failure. It was stated, that the difference of deflections between calculated using transformed section method and experimentally obtained does not exceed 7%. The maximum difference between calculated and experimentally obtained strains is 20% in the half-span and 12% in the quarter-span.

It was stated, that the transformed sections method is characterized by simplicity of design procedure and reasonable precision in comparison with the K-method, gamma method and shear analogy method.



Scientific Seminar
Design of Timber Structures
By EN 1995-1-1
RTU, November 17, 2016

Acknowledgement

The research leading to these results has received the funding from Latvia state research programme under grant agreement "INNOVATIVE MATERIALS AND SMART TECHNOLOGIES FOR ENVIRONMENTAL SAFETY, IMATEH", project ID 1854, task 3.