

PART 2: PROGRAMME PROJECT INFORMATION

2.1. Project No. 4

Title	<i>Layered wooden composite with rational structure and increased specific bending strength</i>	
Project leader's name, surname	(Phase 2: 01.04.2015 – 31.12.2015)	
Degree	Karlis Rocens	
Institution	Dr. habil. sc. ing.	
Position	Institute of Structural Engineering and Reconstruction	
Contacts	Senior researcher	
	<i>Mobile phone</i>	22023321
	<i>E-mail</i>	rocensk@latnet.lv

2.2. Tasks and deliverables (List all tasks and deliverables that were planned for reporting period, list responsible partner organizations, give status, e.g. delivered/not delivered)

The aim of the project is creation of rational wooden composite with rational structure.

Development of load bearing layered wood composite with rational structure (standard plywood plates do not have rational distribution of material through the thickness and layered material gives an opportunity to create an optimal topology of material distribution through the thickness) that provides increased specific bending stiffness (stiffness to weight ratio), reduced costs, consumption of materials and energy when compared to traditionally used materials (LV Patent No. 14519).

A new type of composite construction will be proposed with cell type hollow ribs and skins of plywood or other material. This type of ribs allows to vary the stiffness of wood composites in a more meaningful way as it is for standard plywood or existing sandwich constructions. Mainly the serviceability limit state was considered in this project as it is reached at lower load than ultimate limit state.

A particular solution of ribs will be created; absolute and specific strength will be given and compared to standard type of constructions (plywood sheets, sandwich panels). A new method of calculations will be developed for designing and usage of the plates with proposed structure.

This solution offers to adjust with load bearing capacity in bending and to reduce consumption of material in less loaded areas of cross section. This leads to a new design methodology for structural design which harmonizes section stress field with material resistance field of the developed structure.

After realization of the project it will be possible to produce ribbed plates with cell type core and to develop the technology of production for small amounts (experimental parties). This material could be widely used in furniture production and for structural applications. At the same time it will give an opportunity to use the

proposed plates in combination with CLT panels in multi-storey wood building industry. Time schedule for project 4 is given in Annex 4-A.

Nr.	Tasks	Deliverable	Responsible partner	Status
1	Development of methodology for determination of bending strength and conceptual experimental investigations of plates with cell type hollow ribs (task ends in the 2nd quarter of year 2016).	Methodology	K. Rocens Institute of Structural Engineering and Reconstruction	In progress
2	Development of methodology for determination of specific bending strength for plates with cell type hollow ribs and determination of values for the most typical geometrical parameters (task ends in the 3rd quarter of year 2016).	Methodology	K. Rocens Institute of Structural Engineering and Reconstruction	In progress
3	Work-out of plate models with most typical types of hollow cell type ribs and experimental investigations to get specific strength in bending, consumption of materials, energy consumption and costs (task ends in the 2nd quarter of year 2017).	3 types of plates	K. Rocens Institute of Structural Engineering and Reconstruction	In progress

The development of calculation method for plates with cell type core has been proceeded in second phase of the project.

Load bearing capacity in bending has been determined for the plates with cell type core and supports oriented in orthogonal direction of ribs based on MATLAB code which is developed in framework of the project. This MATLAB code automatically generates the input files for ANSYS FEM software in parametric Design language (APDL) providing possibility to calculate the stiffness and to determine the load bearing capacity in bending of a plate depending on characteristics of materials and geometry of structure for the necessary boundary. The results practically do not differ when compared to the results obtained from experimental investigations in case when the rigid connection between ribs and skins is provided.

The methodology has been developed for shear and tensile strength determination for specific specimens with narrow glued line-joint between plywood surface and edges of ribs. Experimentally investigated more than 300 specimens. Obtained results give an opportunity to design the load bearing capacity in bending for plates with the supports oriented in orthogonal direction of ribs by taking into account the characteristics of geometry and deformations.

The laboratory equipment has been made for the manufacturing of cell type hollow ribs and the plates with these ribs. More than 10 plates with cell type hollow ribs have been manufactured and experimentally investigated. Numerical determination of specific load bearing capacity in bending have been done for the case when the plates is bent in the direction of ribs. More detailed information about the results in achieving the object have been reflected in 4 scientific articles and in 2 patents.

The required amount of research in second phase of project for the realization of project aim has been done completely.

In case of non-fulfillment provide justification and describe further steps planned to achieve set targets and results

-

2.3. Description of gained scientific results

(Describe scientific results achieved during reporting period, give their scientific importance)

Task	Deliverables
<p><i>1. Development of methodology for determination of bending strength and conceptual experimental investigations of plates with cell type hollow ribs (task ends in the 2nd quarter of year 2016).</i></p>	<p><i>Method of calculations of load bearing capacity in bending when the supports are oriented in orthogonal direction of ribs.</i></p> <p><i>Shear and tensile ultimate strength of narrow glued line-joint between the plywood surface and the edge of ribs.</i></p> <p><i>Conceptual analytical and experimental investigations of load bearing capacity in bending (for the supports oriented in orthogonal direction of ribs).</i></p>
<p>Continuous the development of methodology for determination of bending load bearing capacity (started in phase 1).</p> <p>On the basis of the methodology for determination of plate's load bearing capacity in bending specially developed software in MATLAB environment, which automatically generates input file code in ANSYS ADPL and in a parametrical way defines the geometry of plate, properties of materials and applied boundary conditions. ANSYS finite element module calculates the stiffness of a plate and stress-strain field by using this code and generates database of strength and stiffness results depending on geometry of plates. This database is used to train artificial neural network which is used to evaluate the objective function that is used for optimization with genetic algorithm.</p>	

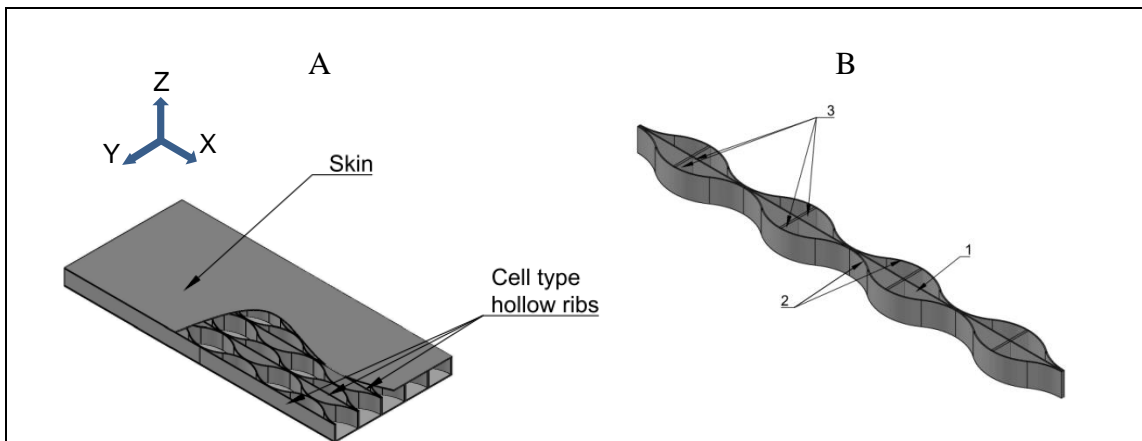

Figure 1. Structure of plate with cell type core: A – structure of a plate; B – structure of one cell type hollow rib with wooden laths. 1 – straight rib part; 2 – waved rib parts; 3 – shear rib laths.

Two different cases have been taken for ANSYS ADPL – plate's behavior when the supports are oriented in orthogonal direction (first case) or in parallel direction (second case). As the experiments show linear bending behavior till fracture for the first case whereas for the second case it is linear only till 30% of ultimate load. Therefore, it is required to take into account nonlinear mechanical properties of glued joint and plywood with crack development in the joint and area near the joint. This nonlinear model of calculations can be used for rational design of energy absorption and vibration damping structures.

The plate is designed in two levels. In the first level the plywood elements (ribs and skins) were designed by using SHELL181 finite elements which are based on Kirchoff-Love (for curved thin ribs) or Mindlin-Reissner theory (for thick plywood elements).

In the second level the ribs (and insulation material if needed) are replaced with one homogenized middle layer (thickness equal to the height of ribs) with anisotropic properties that are obtained from results at first level and numerical homogenization. For the analysis of plate in orthogonal direction to ribs for the homogenized middle layer nonlinear properties (modulus of elasticity and shear modulus) depending on the loads is determined. For the complicated geometry finite elements with homogenized middle layer are used. These elements are based on Reissner-Mindlin shear deformation theory. If the geometry and restrictions are relatively simple, an analytical solution of plates bending problem that is described by partial differential equations is obtained.

Nonlinear behavior of glued joint which is required to take into account for the design of plate's behavior in orthogonal direction of ribs, is simulated by using the cohesive finite element that takes into account the crack development in glue layer. It is realized with INTER20X finite elements in ANSYS environment that simulates separation process in glued joint. In calculations the corresponding interfacial separation δ (displacement jump across the interface) is defined with division in normal δ_n and tangential (shear) δ_t separation. The ultimate normal σ_{max} and ultimate tangential stresses τ_{max} . The cohesive zone model is described with exponential function (TB,CZM,,,EXPO) with the required input data (TBDATA,1, σ_{max} , $\bar{\delta}_n$, $\bar{\delta}_t$,),

if the INTER20X elements are used.

The experimental investigations were made to determinate the required input data for calculation model. In both cases (to determinate the tension and shear properties) special specimens were made that describes the shear and tension behavior of glued joint between plywood surface and plywood edge. Both types of specimens were tested in tension by using loading machine (fig. 2).

For the specimens the tension grips were used to apply force. Displacement (of grips)- load curve was recorded. The double lap specimen was created to determine the shear strength of specimen with 5 mm gap between both rib elements (fig. 2 A). The overlap was created symmetrically on both sides of specimen. For all joints the polyvinyl acetate (Vincent's Polyline PVA D3) glue was used that provides water resistant connection of class D3 according to EN 204.

The series of specimens differ to each other with the thicknesses (4.0; 6.5 and 9.0 mm) and the fiber orientation of surface layer (0° and 90°) of ribs and skins. More than 300 specimens were investigated. Mean shear strength was determined $7.18 \pm a$ MPa (a – difference between mean value and upper and lower value of confidence interval of mean value depending on the value of probability of level of confidence), mean displacement at fracture was $0.63 \pm a$ mm.

The special series of specimens (fig. 2 B) were made to determine the tensile strength of specimens with various orientations of the outer fiber of plywood and various thicknesses of plywood. The mean tensile strength for plywood edge to surface was determined 3.53 MPa and the mean displacement at fracture was $0.14 \pm a$ mm.

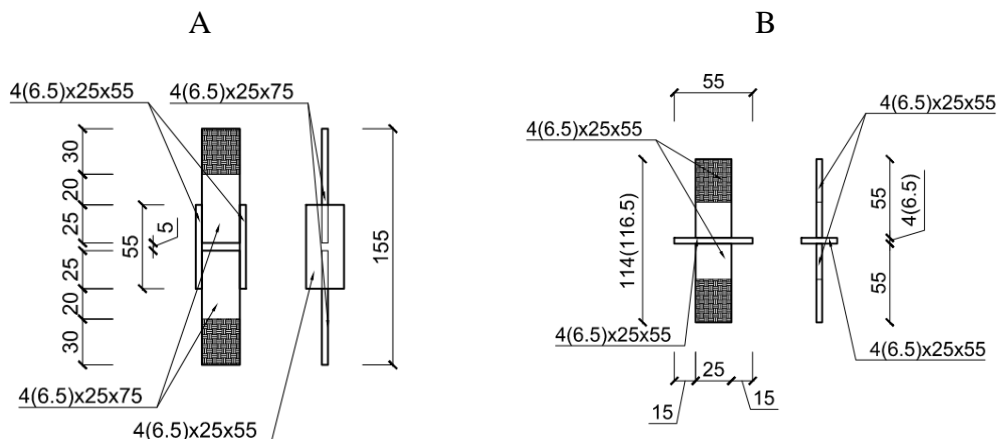

Figure 2. Specially made specimens for determination of ultimate shear and tensile strength of glued joint: A – specimen for shear strength determination of glued joint; B – specimen for tensile strength determination of glued joint.

The distribution that is close to the normal distribution was determined by using statistical analysis of specimen series (fig. 3). For case A: asymmetry – 0.10; excess – 3.00; correlation to the normal distribution – 0.9922. For case B: asymmetry – 0.07; excess – 2.52; correlation to the normal distribution – 0.9945.

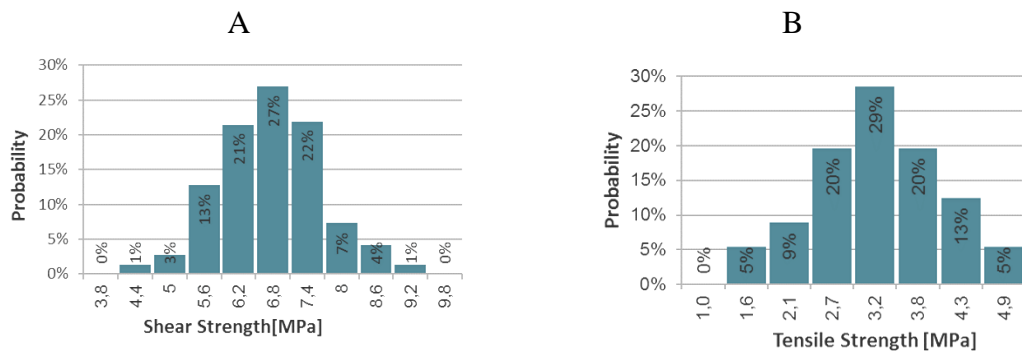

Figure 3. Histograms of plywood edge-to-surface glued joint strength: A – probability distribution of ultimate shear strength; B – probability distribution of ultimate tensile strength.

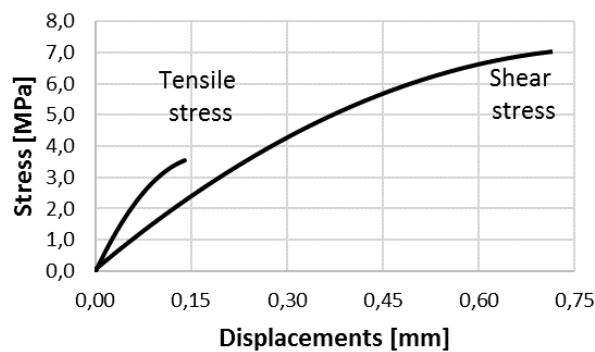

Figure 4. Stress-displacements characteristic curves of glued joints for determination of shear strength (for series with rib plywood with thickness of 6,5 mm and skin plywood with thickness of 4,0 mm with fiber direction same as applied force direction) and tensile strength (for series with rib plywood with thickness of 6,5 mm and skin plywood with thickness of 4,0 mm with fiber direction orthogonal to applied force direction).

Part of experimental results are published in <http://iopscience.iop.org/article/10.1088/1757-899X/96/1/012048>.

The properties of materials and the glued joint (tension and shear) tests were done in laboratory of Institute of materials and structures by using INSTRON E3000.

More than 10 plates (with thickness 25, 50 and 100 mm with cell type core) were investigated in four-point bending (EN 789). For conceptual tests of plates with cell type core in short term loading (supports oriented in orthogonal direction of ribs) the deflections are proportional to the applied load and numerical investigations practically coincide with experimentally achieved results (difference <5%). The deflection of plates when the longitudinal direction of a plate is in direction of ribs, was determined experimentally according to LVS EN 789:2000 Timber structures – Test methods – Determination of mechanical properties of wood based panels. The methodology should be developed for the case when supports are in parallel direction of ribs.

Second phase of the first task (task ends in the 2nd quarter of year 2016) is successfully done according to time schedule.

<p><i>2. Development of methodology for determination of specific bending strength for plates with cell type hollow ribs and determination of values for the most typical geometrical parameters (task ends in the 3rd quarter of year 2016).</i></p>	<p><i>Methodology of calculations for specific load bearing capacity in bending (load bearing capacity to one mass unit) for plates with cell type core (for the supports oriented in orthogonal direction of ribs).</i></p>
<p>The specific load bearing capacity in bending has been numerically determined for the plates with cell type core depending on thickness of a plate and the geometrical parameters of cell type hollow rib. The comparison was made for specific load bearing capacity of plates that consist of a) straight rib part and curved rib parts; b) only curved rib parts; c) only straight rib parts to the massive plywood with equivalent thickness. For the ribbed plates with various thicknesses of straight rib part were analyzed.</p> <p>It has been established that the outer ply of curved rib part has minor influence on the stiffness of a plate in case with the supports oriented in orthogonal direction of ribs. For thickness of ribbed plates less than 1/20 of span (supports in orthogonal direction of ribs), the specific stiffness practically is the same for all investigated ribbed plates. If the thickness increases more than 1/20 of span, highest load bearing capacity in bending for plates with cell type core is obtained.</p> <p>The developed method of calculations gives an opportunity to compare the efficiency of core for providing required load bearing capacity in bending that characterizes the efficiency of material consumption.</p> <p>The influence of geometrical parameters on a plate's specific bending stiffness has been determined. The most influence to specific stiffness of plates (stiffness to unit mass for given cross section) in longitudinal direction of a plate (fig. 5) has not only the thickness of hollow rib but also straight rib part and the width of the hollow rib.</p> <p>Specific load bearing capacity in bending for the plates with cell type hollow ribs is obtained numerically and compared to standard plywood and to the plates with straight ribs. The results show that by increasing the thickness of a plate the benefit of cell type hollow ribs increases. This is described in publication http://journals.ru.lv/index.php/ETR/article/download/633/609 that shows how the stiffness of a plate changes depending on thickness of a plate, geometry of waves and dimensions of plywood.</p>	

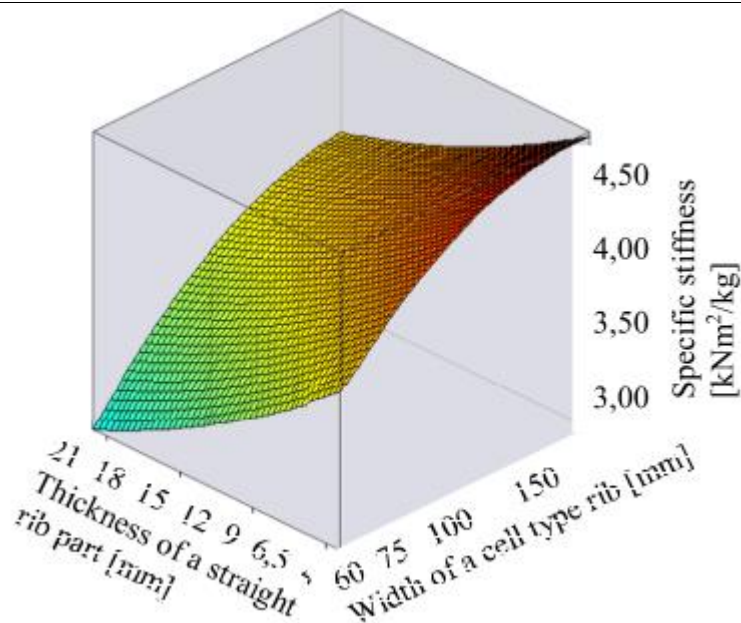

Figure 5. Specific stiffness of a strip with width of 1 m depending on the thickness of straight rib part and width of a cell type rib (span – 1.5 m; thickness of a plate – 3 cm; number of waves along the length – 3; thickness of skins and waved rib parts – 4.0 mm).

The analysis shows that specific load bearing capacity in bending for the ribbed plates is twice as big as it is for standard plywood. Detailed analysis of specific load bearing capacity in bending for various thicknesses of plate and the curvature of waved rib part is planned in next phase of project.

The part of the second task (task ends in the 3rd quarter of year 2016) planned in second phase is successfully done according to time schedule.

3. Work-out of plate models with most typical types of hollow cell type ribs and experimental investigations to get specific strength in bending, consumption of materials, energy consumption and costs (task ends in the 2nd quarter of year 2017).

The laboratory equipment for production of plates and pre-product of cell type hollow ribs. More than 10 plates have been made and experimentally investigated.

The laboratory equipment (fig 6 A) has been made for production of plates and pre-product of cell type hollow ribs. Hydraulic jack (50 kN) was used to apply the load. The dynamometer was used to measure the applied load and to calculate the pressure on plates with accuracy of ± 0.01 MPa. The movable plate provides uniformly distribution of pressure along the fixed plane. With this laboratory equipment can be produced plates with dimensions of 1500×850 and thickness up to 250 mm. With special adaptation (fastening the guides) it is possible to use it for the manufacturing of ribs according to the patent LV15083 achieved in a framework of project. The produced forms (fig. 6 B and C) was sawn in strips which width is equal to the height of a ribs and the specimens were made with various thicknesses. The experimental investigations were done for these plates to the first validation of methodology of calculations.

The laboratory equipment made in framework of project allows to produce

plates with various thicknesses (up to 250 mm) and to evaluate the influence of technology factors on production quality and form stability to plate's resistance against the behavior when resisting applied loads. Meanwhile it gives an opportunity to produce and test a different structural timber materials and structural elements.

The pre-products and first experiments with plates of three different thicknesses (25, 50 and 100 mm) have been made. After evaluation of produced plates no warping deformations were detected.

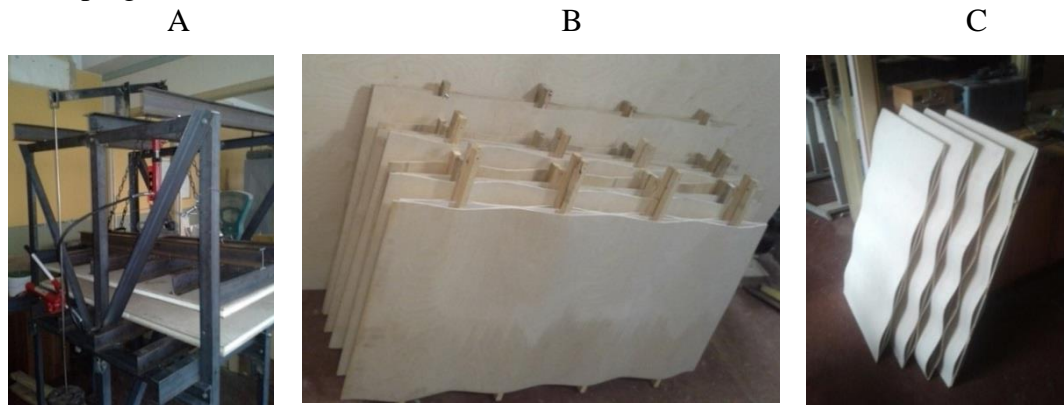

Figure 6. The laboratory equipment and glued pre-product of ribs: A – laboratory equipment for production of plates and rib pre-products; B – pre-products of ribs with glued laths; C – pre-products of ribs without glued laths.

It is shown that experimental investigations coincide to the theoretically calculated and practically does not differ that shows to possibility to produce series of plates with cell type hollow ribs with small variation of mechanical properties. The principles of technology (e. g. bond pressure on glued butt joints) is successfully made and should be specified in detail during next phases.

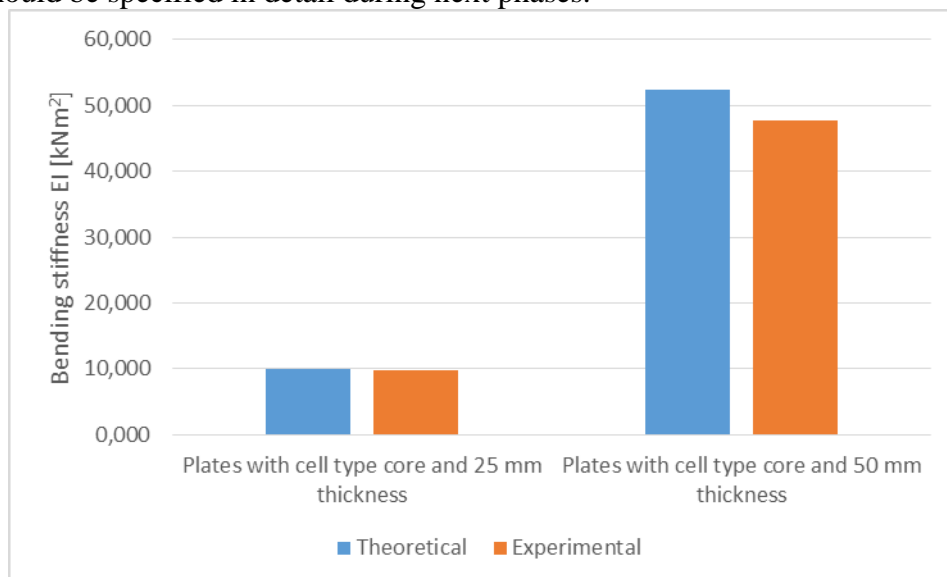

Figure 7. Experimentally and numerically obtained bending stiffness of plates with cell type core. Width of plates is 1m and thickness of 25mm and 50mm. All plywood elements are made of Riga Ply plywood (span 110cm; thickness of skins- 4,0mm; thickness of flat ribs- 6,5mm; thickness of curved ribs- 4,0mm).

To expand the practical use of this material additionally to the planned tasks were done the research about MDF plates which would be possible to use for skins

and ribs <http://link.springer.com/article/10.1617%2Fs11527-015-0769-1>. As well additional research was carried out for the influence of temperature and moisture flow along the plates thickness on the wooden material ribs and their behavior – <http://iopscience.iop.org/article/10.1088/1757-899X/96/1/012048>.

For the assigned application in first phase of project is received patent LV14979 „Method for producing ribbed plates” (K. Rocens, A. Kukule, G. Frolovs, J. Sliseris, G. Berzins) – <http://www.lrpv.gov.lv/sites/default/files/20150620.pdf>. Additionally, was assigned patent application and received patent LV15083 “Method and equipment of production for ribbed composite plate with goffered wood-based core” (K. Rocens, G. Frolovs, A. Kukule, J. Sliseris) – <http://www.lrpv.gov.lv/sites/default/files/20151220.pdf>.

The part of the third task (task ends in the 2nd quarter of year 2017) planned in second phase is successfully done according to time schedule.

The project personal salary makes 24 830 EUR (bruto salaries – 20 376 + social taxes – 4454) in reporting period.

The following research is planned to be made according to time schedule (Annex 4-A).

2.4. Further research and practical exploitation of the results

(Describe further research activities that are planned, describe possibilities to practically exploit results)

It is planned to continue those tasks already started in previous phases. Two additional tasks planed in framework of project will be started:

4. Recommendations work out for design of geometrical parameters of plates with hollow cell type ribs.
5. Recommendations’ work out manufacturing and ‘work in’ technology principles and produce plates’ demonstration models.

All tasks related to practical exploitation of the results will be done and shown according to time schedule given in Annex 4-A.

2.5. Dissemination and outreach activities

(Describe activities that were performed during reporting period to disseminate project results)

Published papers in scientific journals:

1. Sliseris J., Andrae H., Kabel M., Wirjadi O., Dix B., Plinke B. Estimation of Fiber Orientation and Fiber Bundles of MDF. – Materials and Structures, 2015, ISSN 1359-5997. – 1 – 10 p. – <http://link.springer.com/article/10.1617%2Fs11527-015-0769-1>

Published papers in international conference proceedings (with oral presentation in related conference):

1. Frolovs G., Rocens K., Sliseris J. Comparison of a Load Bearing Capacity for Composite Sandwich Plywood Plates. – 10th International scientific and practical conference „Environment. Technology. Resources”, Rezekne, 18.06. – 20.06.2015 – <http://journals.ru.lv/index.php/ETR/article/download/633/609>
2. Frolovs G., Rocens K., Sliseris J. Glued Joint Behavior of Composite Plywood Plates with Cell Type Core. – 2nd International Conference „Innovative Materials, Structures and Technologies”, Riga, Latvia, 30.09. – 02.10.2015 – <http://iopscience.iop.org/article/10.1088/1757-899X/96/1/012048>

3. Kukule A., Rocens K. Prediction of Moisture Distribution in Closed Ribbed Panel for Roof. – 2nd International Conference „Innovative Materials, Structures and Technologies”, Riga, Latvia, 30.09. – 02.10.2015 – <http://iopscience.iop.org/article/10.1088/1757-899X/96/1/012034>

Patents:

1. Rocens K., Kukule A., Frolovs G., Sliseris J., Berzins G. LV14979 „Method for producing ribbed plates” – The Official Gazette of the Patent Office of the Republic of Latvia 20.06.2015, pp 785 – <http://www.lrpv.gov.lv/sites/default/files/20150620.pdf>
2. Rocens K., Frolovs G., Kukule A., Sliseris J. LV15083 “Method and equipment of production for ribbed composite plate with goffered wood-based core”. – The Official Gazette of the Patent Office of the Republic of Latvia 20.12.2015, pp. 1749. – <http://www.lrpv.gov.lv/sites/default/files/20151220.pdf>

Submitted and accepted abstracts for international scientific conferences:

1. 12th international conference “Modern Building Materials, Structures and Techniques” in Vilnius, Lithuania, on 26–27 May, 2016
 - I. Frolovs G., Rocens K., Sliseris J. Shear and tensile strength of narrow glued joint depending on orientation of plywood plys
 - II. Kukule A., Rocens K., Lukasenoks A., Frolovs G. Change of Moisture Distribution in Ribbed Plate with Different Opposite Surface Temperatures
 - III. Sliseris J., Gaile L., Pakrastins L. Deformation process numerical analysis of T-stub flanges with pre-loaded bolts.
2. Confirmation of participating with 3 papers in International Conference “Advanced Construction” in Kaunas, Lithuania on 6-7 October, 2016
 - I. Frolovs G., Rocens K., Sliseris J. Stress state analysis of plates with cell type ribs under loading.
 - II. Kukule A., Rocens K. Determination of Moisture Distribution in Ribbed Plates Induced by the Temperature Gradient
 - III. Sliseris J., Gaile L., Pakrastins L. Non-linear buckling analysis of steel frames

Supervised doctoral thesis:

1. G. Frolovs “Calculations of rational wooden composite structures and their elements”;
2. Kukule “Behavior of plywood ribs in various conditions of moisture”

Defended master thesis:

1. Ucelnciece “Impact of snow loads on different types of roof shapes” (Supv. D. Serdjuks, G. Frolovs);
2. Zukovska-Kecedzi, „Wind load action depending on the roof’s shape” (Supv. D. Serdjuks, A. Kukule);

Results of the project popularization in phase 2:

1. The representatives of the project have been participated in all meetings of State Research program IMATEH about the process and state of art of projects and program.
2. In framework of program is organized international scientific conference IMST 2015 (30.09. – 02.10.2015).
3. Seminar “Possibilities of cooperation with German company MC Bauchemie” (10.11.2015).
4. Seminar “Research and activity directions in commercialization project’s results. Information for representatives of Latvian Academy of Science” (27.11.2015).
5. Seminar “Progress in research of ribbed plywood bending load bearing capacity. Discussion with representatives of industry” (11.12.2015).

Detailed information about activities and actualities of 4th Project has been published in the IMATEH home page <http://imateh.rtu.lv/>.

Time schedule for project 4.
Layered wooden composite with rational structure and increased specific bending strength

	2014		2015				2016				2017			
	III	IV	I	II	III	IV	I	II	III	IV	I	II	III	IV
1. Methodology work-out for determination of bending strength and conceptual design of plates with cell type hollow ribs	x	x	x	x	x	x	x	X						
1.1. work-out of calculation methodology	x	x	x	x	x	x	x	X						
1.2. determination of specimens' mechanical properties				x	x	x	X							
1.2.1 Development of shear Resistance determination methodology for glued joint joint between plywood surface and edge.				x	x	X								
1.2.2 Determination of deformability and strength of plates in bending					x	x	X							
2. Methodology work-out for determination of specific bending strength for plates with cell type hollow ribs and determination of values for the most typical geometrical parameters.					x	x	x	x	X					
2.1. work-out of calculation methodology					x	x	x	X						
2.2. determination of specific bearing capacity							x	x	X					
3. Work-out plate models with most typical types of hollow cell type ribs and experimental investigations to get specific strength in bending, consumption of materials, energy consumption and costs.				x	x	x	x	x	x	x	x	X		
4. Recommendations work out for design of geometrical parameters of plates with hollow cell type ribs.									x	x	x	x	X	
5. Recommendations' work out manufacturing and 'work in' technology principles and produce plates' demonstration models.							x	x	x	x	x	x	x	X
6. Publications, Scopus													1	
7. Conferences						1			1				1	
8. Supervision of doctoral thesis and master's thesis	x	x	x			x	x		x	x	x		x	x