

International Conference  
SPbUCEMF 2015  
18-20 March, 2015



**RIGA TECHNICAL UNIVERSITY**

**INSTITUTE OF STRUCTURAL ENGINEERING AND RECONSTRUCTION**

**A.Vilguts, D.Serdjuks, L.Pakrastins**

# **Design Methods of Elements from Cross-Laminated Timber Subjected to Flexure**

**RIGA 2015**



International Conference  
SPbUCEMF 2015  
18-20 March, 2015

## Content

- 1. Introduction;**
- 2. Aim and tasks of investigation;**
- 3. Design methods of CLT elements subjected to flexure;**
- 4. Verification of design methods by experiment;**
- 5. Verification of design methods by FEM;**
- 6. Design methods Analysis of CLT elements subjected to flexure;**
- 7. Conclusions;**
- 8. Acknowledgement.**

## Introduction

### Main advantages of CLT

- Mechanical properties comparable with steel and reinforced concrete;
- Shorter manufacturing and construction time;
- CLT is suitable for structural elements subjected to flexure with spans from 4 to 9 m;
- CLT is suitable for high (up to 30 floors) and middle raised buildings;
- Reduced CO<sup>2</sup> emissions.

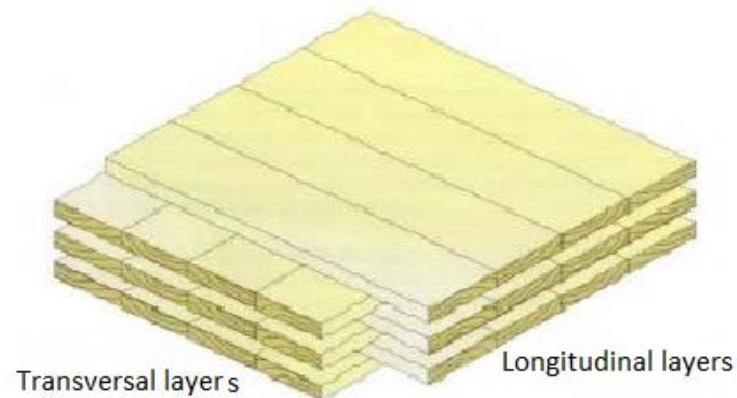

## Introduction

### Multy-stories buildings with the using of CLT



*a) Residential buildings in London.*



Up to 30 Stories



*b) Design of residential buildings with up to 30 stories.*

## Introduction

### Typical floor structure for multi-stories buildings with the using of CLT

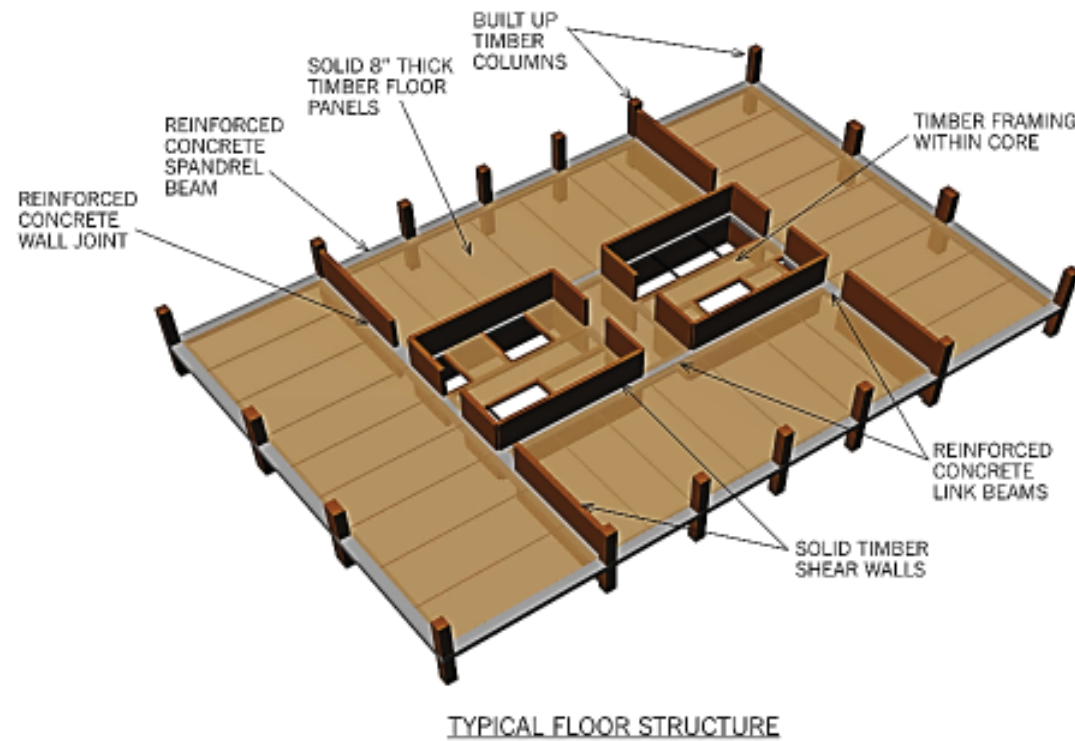



International Conference  
SPbUCEMF 2015  
18-20 March, 2015

## **Introduction**

### **Bridge structures with the using of CLT**



**Pedestrian bridges with the decking made of CLT (Feldbach, Austria)**



International Conference  
SPbUCEMF 2015  
18-20 March, 2015

## **Aim and tasks of investigation**

The **aim** of current investigation is to consider and analyse design methodology of CLT elements subjected to flexure.

Design methodology which is described in EN 1995–1–1 must be verified by laboratorian experiment and FEM.



International Conference  
SPbUCEMF 2015  
18-20 March, 2015

## **Design methods of cross – laminated timber elements subjected to flexure**

**Two following methods** are used for the designing of CLT structural members subjected to flexure:

- Effective strength and stiffness method.
- Transformed section method.

**Checked for the CLT structural member subjected to flexure:**  
**The ultimate limit state (ULS)**

- Check of bending stresses;
- Check of shear stresses.

**Serviceability limit state (SLS)**



## Design methods of cross – laminated timber elements subjected to flexure

### Effective strength and stiffness method

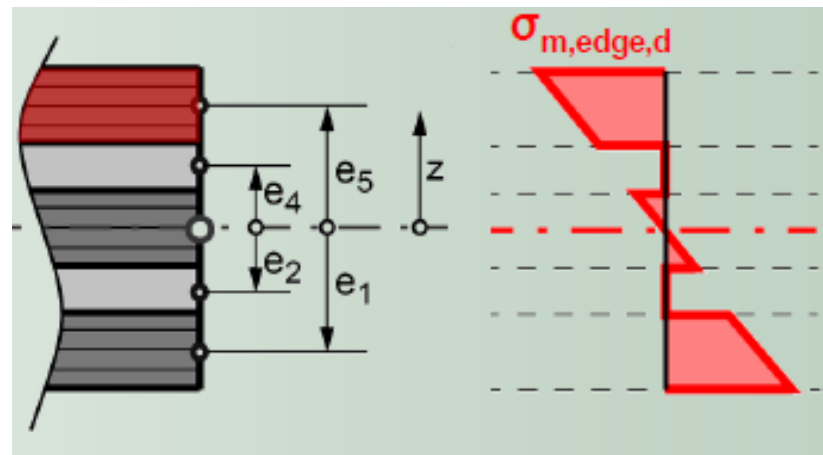

Distribution of normal stresses in the CLT element's cross-section:  $e_{1,2,3,4}$  – distances from the neutral axis to the middle of current layer;  $\sigma_{m, edge, d}$  – normal stresses acting in the edge fiber



International Conference  
SPbUCEMF 2015  
18-20 March, 2015

## Design methods of cross – laminated timber elements subjected to flexure Effective strength and stiffness method

Maximum value of bending stresses acting in the edge fibers of outer layers of CLT panels:

$$\sigma_{edge,d} = \frac{M_{max,d}}{K_{CLT}} \cdot \frac{a_{CLT}}{2} \cdot E_{i=5}$$

where  $M_{max,d}$  – design value of maximum bending moment;  $a_{CLT}$  – CLT plates height;  $K_{CLT}$  – effective stiffness of CLT plate;  $E_{i=5}$  – modulus of elasticity of the each layer in longitudinal direction.

$$K_{CLT} = \sum_{i=1}^n (J_i \cdot E_i) + \sum_{i=1}^n (A_i \cdot e_i^2 \cdot E_i) = (EI)_{ef} = E_0 \cdot \frac{h^3 \cdot b}{12} \cdot k_i,$$

where,  $E_i$ ,  $A_i$  – modulus of elasticity and area of cross-section of separate layer;  $I_i$  – moment of inertia of separate layer relatively it own main axis;  $E_0$  – modulus of elasticity of timber in longitudinal direction;  $h$  – total thickness of the plate;  $k_i$  – composition factor which depends from the certain loading conditions.



International Conference  
SPbUCEMF 2015  
18-20 March, 2015

## **Design methods of cross – laminated timber elements subjected to flexure** **Transformed cross-section method**

Transformation of cross – section is based on the relation of modulus of elasticity of the layers in longitudinal direction:

$$n = \frac{E_{90}}{E_0}$$

where  $E_0$  – modulus of elasticity of timber in longitudinal direction ;  $E_{90}$  – modulus of elasticity of timber in transversal direction.

## Design methods of cross – laminated timber elements subjected to flexure Transformed cross-section method

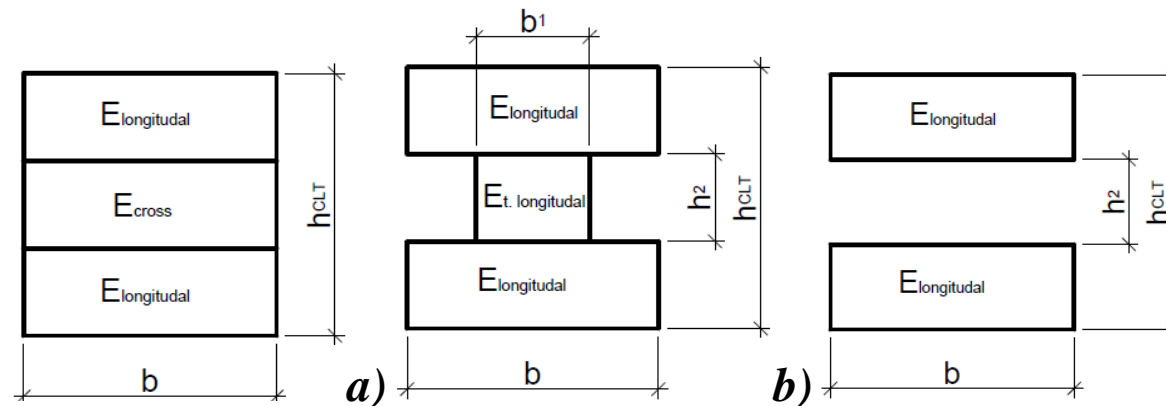

Transformation of cross – section: *a*) – middle layer is taken in to account; *b*) – middle layer is not taken in to account.

Obtained transformed double-tee cross-section then is considered as glued homogenous cross-section. Checks of ultimate limit state (ULS) and serviceability limit state (SLS) must be conducted basing on the recommendations of EN 1995–1–1.

## Verification of design methods by experiment

Two CLT plates with the length and width equal to 2 and 1m, correspondingly and thickness in 95 mm were considered.

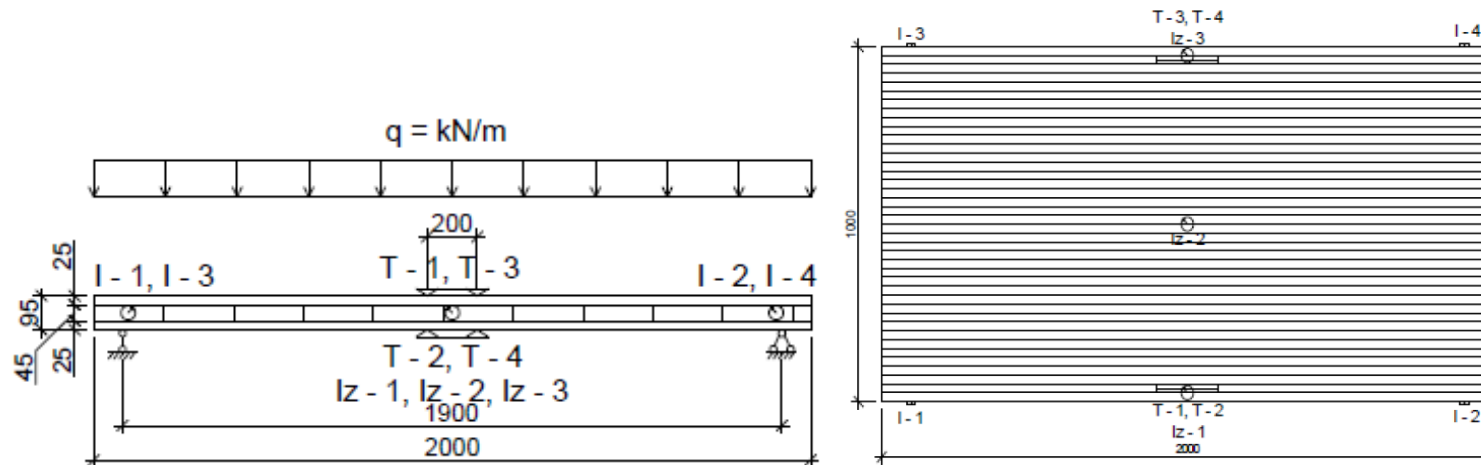

Four strain gauges T-1, T-2, T-3, T-4, three deflectometers Iz – 1, Iz – 2, Iz – 3 and four indicators I – 1, I – 2, I – 3, I – 4 were used for this purpose.

## **Verification of design methods by experiment**

### **Loading of specimens**

Intensities of uniformly distributed loads changes within the limits from 1 to 7.5 kN/m<sup>2</sup> with the step equal to 0.5 or 1.0 kN/m<sup>2</sup>.



***a)*** – CLT plate before loading



***b)*** - CLT plate under the load in 7.5 kN/m<sup>2</sup>

## Verification of design methods by FEM method

The FEM softwares **REFM 5.0** and **ANSYS v14** were used for the CLT plate with dimensions in plan 2x1 m and thickness in 95 mm.

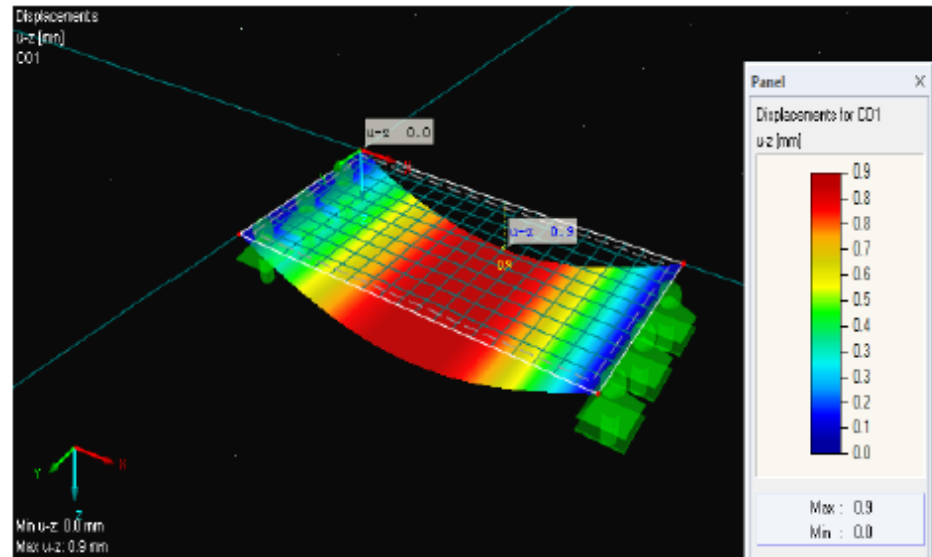

a)

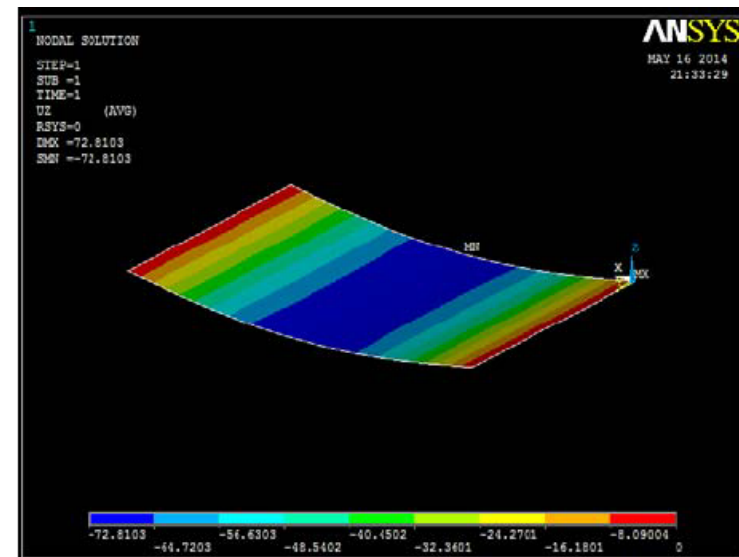

b)

Maximum vertical displacements of CLT plate, which were determined by the softwares:

a) REFM5.0. ; b) ANSYS v14

## Design methods Analysis of CLT elements subjected to flexure

The dependence of strains in edge fibers of CLT plates as a function from the load's intensity.

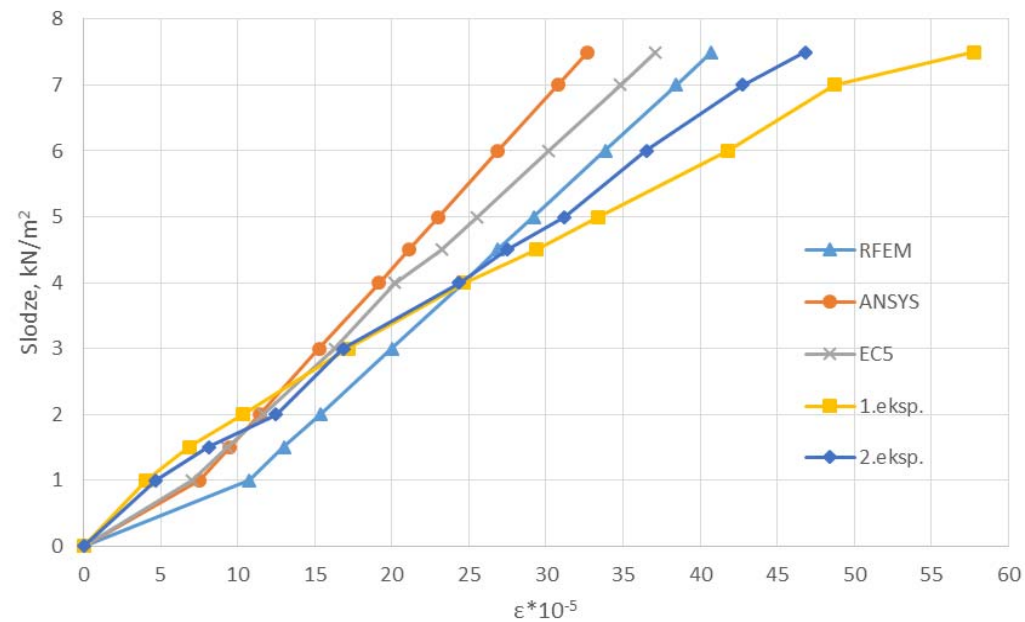



## Design methods Analysis of CLT elements subjected to flexure

The dependences of *a*) maximum vertical displacements in the middle of the span of CLT plates and *b*) relative displacements of outer and middle layers of CLT plate as a function from the load's intensity.

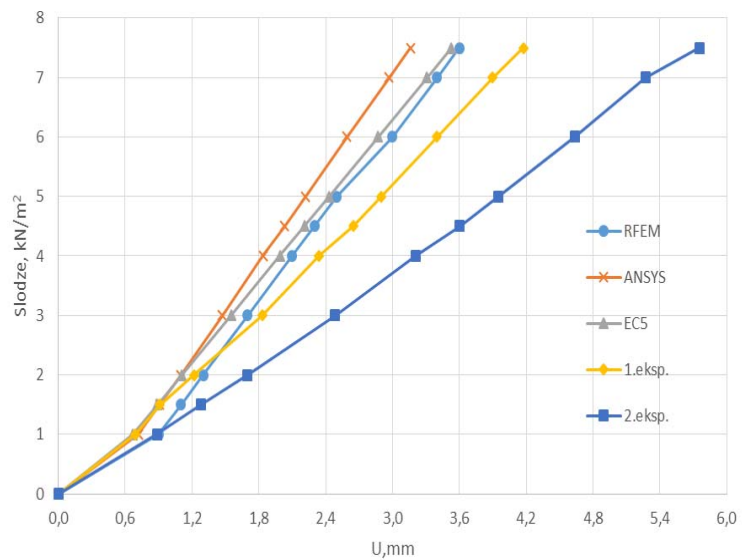

*a)*

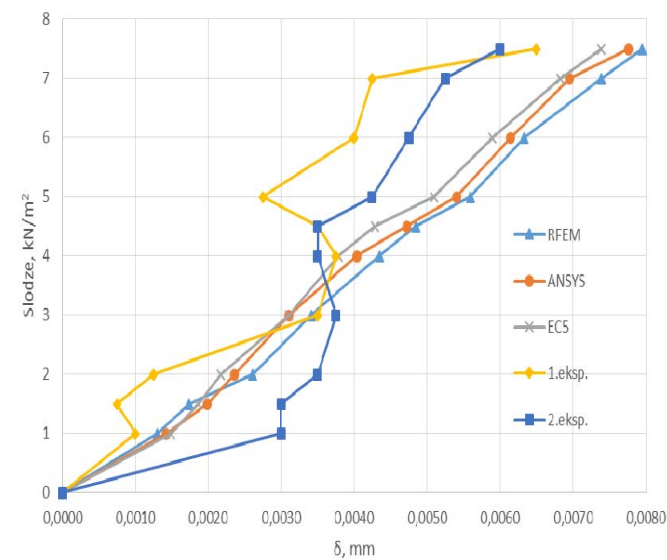

*b)*



International Conference  
SPbUCEMF 2015  
18-20 March, 2015

## **Design methods Analysis of CLT elements subjected to flexure**

The maximum differences between the results obtained by the design methods and physical experiment are following:

- maximum bending stresses, acting in the edge fibers – 22%;
- horizontal relative displacements of outer and middle layers of CLT plate –17%;
- maximum vertical displacements in the middle of the span –31%.

The maximum differences between the results obtained by the design methods and softwares REFEM and ANSYS v14 are following:

- maximum bending stresses, acting in the edge fibers – 10%;
- horizontal relative displacements of outer and middle layers of CLT plate –7%;
- maximum vertical displacements in the middle of the span – 3%.

The differences between the results obtained by the design methods and physical experiment can be explained by the deviation from the technological requirements during producing of both specimens. So, necessary pressure during gluing of the CLT panels must be at least  $600\text{kN/m}^2$ , but in reality it was 33% less and, probably, necessary quality of glue joints was not provided.



International Conference  
SPbUCEMF 2015  
18-20 March, 2015

## Conclusions

Analysis of design methods of cross-laminated timber elements subjected to flexure was carried out. The transformed sections and effective strength and stiffness methods were checked analytically and experimentally for cross laminated timber panels.

The maximum differences between the results obtained by the design methods, physical experiment and softwares REFEM 5.0 and ANSYS v14 were equal to 31 and 10%, correspondingly.

So, the transformed sections and effective strength and stiffness methods enable to describe behaviour of CLT elements subjected to flexure with the available accuracy. Result difference for cross laminated timber plates for load bearing capacity, relative displacements of outer and middle layers and maximum vertical displacements varies up to 10%.



International Conference  
SPbUCEMF 2015  
18-20 March, 2015

## **Acknowledgement**

The research leading to these results has received the funding from Latvia state research programme under grant agreement "Innovative Materials and Smart Technologies for Environmental Safety, IMATECH". Project Y8085.3.3.